

**SINGAPORE PRIMARY SCHOOLS SPORTS COUNCIL
WUSHU RULES AND REGULATIONS FOR NATIONAL SCHOOL GAMES 2022**

PREAMBLE

This document outlines the rules and regulations for the conduct of and participation in the National School Games (NSG) 2022. This is subject to possible changes in prevailing national posture. Updates will be communicated to participating schools when required.

SECTION A – ADMINISTRATIVE RULES & REGULATIONS

1 ORGANISATION STRUCTURE AND GOVERNING BODIES

- 1.1 The National School Games (NSG) Wushu competition shall be conducted:
- 1.1.1 as governed by the General Rules and Regulations of the Singapore Primary Schools Sports Council (SPSSC).
 - 1.1.2 as governed by the International Wushu Competitions Rules (Nov 2005) for Individual Events and (Nov 1999) for Group Events and adopted by the Singapore Wushu Dragon & Lion Dance Federation (SWDLF) unless otherwise stated in the SPSSC General Rules and Regulations and its games rules.
 - 1.1.3 adhering to the Baseline Safety Standards for the NSG.
 - 1.1.4 In the event that the rules and regulations are modified for safety/developmental reasons to suit the level of our school students, it must be clearly stated in the respective sports rules and regulations.
 - 1.1.5 In the absence of a set of recognised rules to govern the occurrence of situations during the competitions, the National School Games Wushu Organising Committee shall **make the final decision.**
- 1.2 NATIONAL SCHOOL GAMES ORGANISING COMMITTEE (NSGOC) - WUSHU
- 1.2.1 The Wushu NSGOC shall consist of the following:
 - a) The National Convenor,
 - b) The Game Advisor,
 - c) The Zonal Convenors,
 - d) Organising Secretaries and
 - e) Any other co-opted members deemed necessary
 - 1.2.2 The Wushu NSGOC is empowered to appoint sub-committees and individual members to assist in the organisation and running of the NSG competitions as and when required.
 - 1.2.3 The Wushu NSGOC shall have sub-committees to perform the following roles and responsibilities (Terms of Reference for NSGOCs are given in **Annex B** :-
 - a) Technical: Establish, review and update competition rules and regulations for the competitions and other matters necessary to provide for developmentally appropriate NSG competitions.

- b) Competitions: Organise and conduct the competition according to the rules and regulations, and established safety standards.
- c) Recognition, Appeal and Discipline: Manage recognition and discipline structures to support the desired outcomes of the NSG.
- d) Other functions necessary for the successful completion of the NSG sport that the NSGOC is in charge of.

2 AGE GROUPS / DIVISIONS

2.1 All students shall compete in their respective divisions according to their year of birth **with the exception of those born on 1 January who have been given approval for deferment by MOE during P1 registration.** These students will compete in the division with the cohort that they are studying with.

2.1.1 With effect from 2021, students who are born on 1 January and have participated in NSG previously shall follow the rules stated in Para 2.1. This rule will supersede all previous decisions.

2.1.2 This exception in Para 2.1 does not apply to students who are born on 1 January and have repeated a year of study.

2.2 All students can only compete in one division of that particular sport within the same year.

2.3 Students aged 11 can play in either the Senior or Junior Division depending on their level of competency¹ for the following sports:

Division	Age	Year/Date of Birth
Senior Division	11, 12 and 13 years old	1 Jan 2012 1 Jan 2011 --- 31 Dec 2011 1 Jan 2010 --- 31 Dec 2010 2 Jan 2009 --- 31 Dec 2009
Junior Division	9, 10 and 11 years old	1 Jan 2014 1 Jan 2013 --- 31 Dec 2013 1 Jan 2012 --- 31 Dec 2012 2 Jan 2011 --- 31 Dec 2011

2.4 Schools will make the decision based on what they deem to be the appropriate level of play for each 11-year-old concerned (except Basketball, Floorball, Football, Golf, Gymnastics, Hockey, Netball, Rugby, Swimming and Track & Field).

2.5 Age Dispensation

2.5.1 In Wushu, 7-year-olds and 8-year-olds may participate in the Junior Division.

Age Dispensation	7 and 8 years old	1 Jan 2016 1 Jan 2015 --- 31 Dec 2015 1 Jan 2014 --- 31 Dec 2014
------------------	-------------------	--

¹ Participating schools should register their students for the Senior or Junior Division based on the student(s)' level of competency and readiness.

- 2.5.2 Application has to be put forth by parents/guardians, endorsed by the school Principal and submitted to the Wushu NSGOC for follow-up (Refer to **Annex C**).
- 2.5.3 Age dispensation is only applicable to the year of application.

3 ENTRIES

3.1 Senior Division

3.1.1 Each school is eligible to enter only one team in each of the following divisions:

- a) Boys Senior Division
- b) Girls Senior Division
- c) Boys Junior Division
- d) Girls Junior Division

3.2 All entries must be submitted through the Registration Module at <https://nsg.moe.edu.sg/nis/#!/login> on or before the stipulated closing date. This includes details of participants along with the necessary supporting documents.

- a) Baseline Safety Standards Acknowledgement Form
- b) Supporting documents for Special/Transfer case students
- c) Other forms as determined by the Wushu NSGOC

3.3 Appeals for late/ erroneous entries² submitted by schools will be accepted on a case-by-case basis with consensus from the Organising Committee. (Please refer to **Annex D**).

3.3.1 Schools must write in through the Principal, to inform the Convenors of any appeal at least one (1) working day before the next match.

4 REGISTRATION OF PARTICIPANTS

4.1 Each school may be represented by a team in each Division

4.2 If a school is unable to register a full team, it may be represented by individual participant(s). However, if a school chooses not to register the maximum number of participants at the time of registration, the school shall not be permitted to register additional participants subsequently.

4.3 Only in the event that any participant(s) registered is/are transferred or has/have to leave school during the preliminary rounds, the school shall be allowed to replace the affected participant(s).

4.3.1 Schools must write in to inform the Convenors of the replacement at least one (1) working day before the next match.

4.3.2 No replacement of participants is allowed once the competition reaches the semi-final stage or after two (2) games have been played in a single group round league.

4.4 International students can only be registered to play for their school **after** they have been issued with the student passes from the Immigration and Checkpoints Authority (ICA).

² The rule applies to late/ erroneous in entries and registration of participants.

- 4.5 International students who are in the schools on exchange programme are not allowed to represent the school.
- 4.6 Students granted Leave of Absence (LOA) by MOE will be allowed to represent the school.
- 4.7 Registration constitutes representation, that is, once a student is registered to play for a school, he or she is deemed to have represented his or her school. Hence, the student is not allowed to represent another school in the same sport in the same year.

SECTION B – COMPETITION RULES & REGULATIONS

5 COMPETITION FORMAT

- 5.1 There must be a minimum of three (3) registered individuals from three (3) different schools before a competition can be organised. Otherwise, the individual event shall be cancelled.
- 5.2 Each school is allowed to register up to a maximum number of **10** participants per division & gender for the Championships.
 - i) For Individual events: a maximum of 10 participants per division/gender
- 5.4 Individual Event:

5.4.1 Formulated Routine (3-Duan/4-Duan/5-Duan)

Quanshu	Short Weapon	Long Weapon
3-Duan Changquan	4-Duan Broadsword	4-Duan Cudgel
3-Duan Nanquan (Southern Fist)	4-Duan Sword	4-Duan Spear
5-Duan Changquan	5-Duan Broadsword	5-Duan Cudgel
5-Duan Nanquan (Southern Fist)	5-Duan Sword	5-Duan Spear
24-Style Taijiquan	32-Style Taijijian	

3-Duan Changquan and 3-Duan Nanquan (Southern Fist) events are only applicable to the Junior Division

5.4.2 1st International Routine

Quanshu	Short Weapon	Long Weapon
Nanquan (Southern Fist)	Nan Dao (Southern Broadsword)	Nan Gun (Southern Cudgel)
Changquan	Broadsword	Cudgel
42-Style Taijiquan	Sword	Spear
	42-Style Taijijian	

- 5.4.3 A maximum of 2 participants per school are allowed for each individual event.
- 5.4.4 Each participant is allowed to participate in a maximum of **2** different types of individual events (Quanshu, Short Weapon and Long Weapon).

5.6 Timing:

5.6.1 Timing for Individual Event:

- a. Formulated Routine (3-Duan/4-Duan/5-Duan):
No time limit
- b. Formulated Routine (Taijiquan simplified 24-style & 32 Style Taijijian):
Between 2 to 4 minutes.

c. 1st International Routine:

Nanquan, Chanquan and all weapons:
Not less than 1 minute 20 seconds.

Taijiquan:
Between 5 to 6 minutes.

Taijijian:
Between 3 to 4 minutes.

5.7 Routine Stoppage

Athletes who are unable to perform their routine and stop for 10 seconds in the arena will be instructed to abandon their performance upon hearing the whistle from the Head Judge. Athletes will not be allowed to join the queue to re-do the routine. It will be classified as incomplete event and no points will be awarded.

5.8 Scoring System

5.8.1 Individual Events to be scored using (Nov 2005) IWUF Wushu Taolu Scoring System (Refer to **Annex E**)

6 AWARD OF LEAGUE POINTS

6.1 Award of league points is not applicable to Wushu.

7 PRIZES

7.1 The number of prizes to be awarded at the Wushu competition for all Divisions shall be as follows:

No. of Participants	Position/Medals Awarded
3-4	2
5-6	3
7-8	4
9-10	5
11-12	6
13-14	7
15 and more	8

7.2 The form of the medals awarded for all Divisions shall be as follows:

Position	Form of Medals
1 st	Gold
2 nd	Silver
3 rd	Bronze
4 th	
5 th	
6 th	
7 th	
8 th	

7.3 In the event of a tie, the tie shall remain, and prizes will be awarded to the winners.

7.3.1 In the event of a tie in the first place, the next best would be placed third.

7.3.2 In the event of a tie in the second place, there would be no third placing and so forth up till 8th placing

7.4 Achievement Pins (for Junior Division only)

7.4.1 Achievement pins can be awarded up to 50% of participants in the individual event.

7.5 Divisional Placing (for Senior Division only)

7.5.1 Senior Divisional placing will be awarded from 1st to 4th based on the overall points scored in Individual events.

7.5.2 Allocation of points for 1st to 8th position to be used for Senior Divisional placing for schools:

Individual Events:

Placing	Point/s
1 st	9
2 nd	7
3 rd	5
4 th	3
5 th	2
6 th - 8 th	1

7.5.3 In the event of a tie in the total number of points won in Individual events, the total individual points scored in all Individual Events will be used to determine the placing.

7.5.4 If the tie persists, the number of total 1st positions (followed by 2nd, 3rd, 4th, 5th, 6th, 7th, and 8th if necessary) scored in all Individual events will be used to decide the final placing.

8 REPORTING AND GRACE PERIOD

- 8.1 Fifteen minutes (15 min) grace is allowed. The Convenor or his/her representative may at his/her discretion extend this grace period if he/she thinks the extension of grace period is justifiable (e.g., in special cases when delay may be caused by traffic jams, etc). However, the school concerned must contact the Convenor or his/her representative at the venue concerned to inform him/her of the delay. Participant(s) must abide by the decision of the Convenor or his/her representative.

9 POSTPONEMENT

- 9.1 The Convenor or his representative shall, at his/her discretion, decide to postpone a match if he thinks the venue is unfit for play, or for any other valid reasons for which he deems a postponement is in order. Participant(s) must abide by the decision of the Convenor or his/her representative.

10 WITHDRAWAL AND WALKOVER

- 10.1 Any withdrawal or walkover is considered to be contrary to the spirit of the sport.
- 10.2 Schools participating in the NSG should not withdraw or concede a walk-over without a valid reason.
- 10.3 For each withdrawal³ or walk-over, a written explanation duly endorsed by the Principal shall be submitted to the Convenor and the Game Advisor within two (2) working days.

11 ABANDONED GAME

- 11.1 The referee / umpire /match manager is required to submit a written report on an abandoned game within one (1) working day.
- 11.2 For decision on abandoned game, refer to Para 20 on disqualifications.

12 PROTEST

- 12.1 Any clarification on points of laws/rules, must be lodged immediately by the Team Manager (TM) to the referee / umpire / judge. Any decision made by the referee / umpire / judge will be final.
- 12.2 All protests shall be referred to the NSGOC. The protest(s) must reach the Committee within **one (1)** working day following the match to which it relates unless stipulated otherwise in the respective sport's rules. The protest must be in writing and duly signed by the principal. A protest fee of \$150 is to be paid by the school (within 30 days from notification of outcome) if the protest is overruled.
- 12.3 The Wushu NSGOC will deliberate on the protest within five (5) working days. The decision will then be made known in writing to the school concerned.
- 12.4 When there is any conflict of interest, the school(s) involved will not sit in the committee considering the protest.

13 APPEAL (Please refer to Annex F)

- 13.1 Upon the release/disclosure of the decision of the Wushu NSGOC, only schools may appeal to the Council.

- 13.2 Notices of appeal shall be lodged with the Secretary / Secretariat of the Zonal / Central Council within two (2) working days upon receiving the Wushu NSGOC's decision. The appeal must be in writing and duly signed by the Principal or via email sent by the Principal.
- 13.3 An appeal fee of \$300 is to be paid by the school (within 30 days from notification of outcome) if the appeal is overruled.
- 13.4 The Board of Appeal will deliberate on the appeal. The decision of the Board of Appeal shall be final.

14 SUSPENSION

- 14.1 Participant(s) suspended by any one of the following bodies is barred from participating in the NSG for that sport for the period of suspension:
- a) The School
 - b) The Zonal Council
 - c) The SPSSC
 - d) The National Sports Association (NSA) of the sport

15 TEAM MANAGER (TM)

- 15.1 Each participating team/participant(s) must be accompanied by a TM who shall remain with the team/participant(s) throughout the duration of play (Please refer to **Annex G**).
- 15.2 The TM shall be a teacher or School Adult Representative⁴ (SAR) appointed by the participating school. The appointment of an SAR as a TM should be based on the conditions and considerations given in **Annex H**.
- 15.3 TMs are expected to conduct themselves with decorum during competitions.
- 15.4 TMs are not allowed to interfere with the final decision taken by the referee/umpire/judge/official on points of laws/rules after clarification has been sought. If such interference results in disruption of any match, a report shall be made by the Convenor and the matter brought to the attention of the Council for appropriate action.

16 REFEREE / UMPIRE / JUDGE / OFFICIAL / PITCH or COURT MANAGERS

- 16.1 Education Officers, Contract Adjunct teachers, Flexi-adjunct teachers and Allied Educators can serve as officials.
- 16.2 Schools should ensure that their officials are present to fulfil their duties as scheduled by the Convenor and in alignment to the spirit of the Officials' Oath (Please refer to **Annex A** for officials' oath).

17 COACHES

- 17.1 Coaches are expected to conduct themselves with decorum during competitions and in alignment to the code of conduct (**Refer to Annex A**) and spirit of the Coaches Oath (**Refer to Annex A**) during competitions.
- 17.2 Coaches are not allowed to approach the officials to query their decisions. Only TMs are allowed to approach officials to seek clarifications.

⁴ SAR option is only available for the following individual sports: Cross-Country, Fencing, Golf, Gymnastics, Judo, Sailing, Shooting, Swimming, Taekwondo, Tenpin Bowling, Track & Field and Wushu

- 17.3 Schools must ensure that their coaches adhere to the SPSSC Rules and Regulations and the Code of Conduct (Please refer to **Annex A** for coaches' oath).

18 BREACH OF CODE OF CONDUCT BY PARTICIPANTS / TMs / PARTICIPANTS / OFFICIALS / COACHES (refer to Annex I)

- 18.1 A Disciplinary Panel comprising members of the Wushu NSGOC will be formed to investigate the breach, presided by a Principal, who is the Chairman of the Discipline and Recognition Sub-Committee. The Panel may co-opt members outside the Wushu NSGOC, including personnel from the national sports association, to provide technical advice.
- 18.2 Any athlete, coach, official, or spectator found guilty of aggressive behaviour through a fight / assault at the NSG, shall be expelled from the NSG, and be banned from it, for the calendar year of the NSG. This shall also apply to all fights / assaults traced to an NSG competition, either immediately, before, during or after the competition.
- 18.3 An appeal against the decision of the Disciplinary Panel may be submitted by the school (for participants, coaches, and TMs) and/or the official, to the Council, whose decision shall be final (Please refer to Para 13 with regards to the Appeal process).

19 DISQUALIFICATION

- 19.1 A school will be disqualified if:

- a) it fields an ineligible participant who is:
 - i. overaged
 - ii. underaged
 - iii. unregistered
 - iv. suspended (with reference to para 14)
 - v. without a valid student pass
 - vi. not a bona-fide student of the school
- b) its participant(s) are not accompanied by a TM
- c) its participant(s) caused a game / match to be abandoned

- 19.2 All results involving the team which has been disqualified will be considered null and void.

20 ATTIRE

- 20.1 All participants must wear proper wushu attire and footwear (flat sole shoes only) during all competitions.
- 20.2 All participants must adhere to the Specification of Costumes for the various events listed below.

(a) Chang quan routines

Wushu jacket with a Chinese-style upright collar and seven toggle-like buttons down the front and short or long sleeves

(b) Nan quan routines (Southern Fist)

Wushu Chinese-style collarless jacket with seven toggle-like buttons down the front and with short sleeves for girls and sleeveless for boys.

(c) Taiji routines

A long-sleeved jacket of a length not exceeding the participant's Middle fingertip when the arms are straightened and hanging down. Wushu Jacket with a Chinese-style upright collar and seven toggle-like buttons down the front. Participants are not to wear a soft belt for taijijian and taijiquan routines.

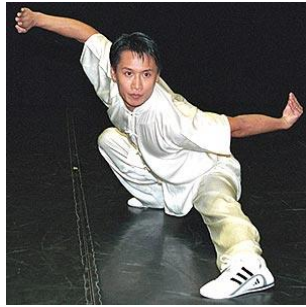

(a) Chang Quan

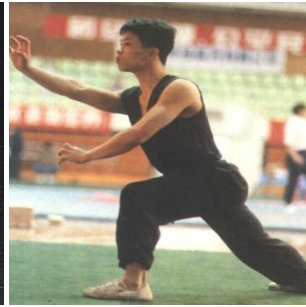

(b) Nan Quan



(c) Taiji Quan

21.4 Girls with long hair must have it tied neatly.

21.5 Failure to comply with 21.1 to 21.4 will result in the deduction of **0.2** points.

WEAPONS SPECIFICATION FOR INDIVIDUAL EVENTS

21.6 All participants must adhere to the weapons specification listed below:

(a) Spear

The whole length of the spear shall not be shorter than that from the participant's fingertips to his sole when he stands erect with his arms raised straight overhead. The spear must be fitted with a tassel.

(b) Cudgel and Southern Cudgel (Nan Gun)

The whole length of the cudgel shall not be shorter than the participant's height.

(c) Sword

The apex of the sword shall not be lower than the top of the performer's ear when it is held using backhand with the arm straightened and hanging down and the elbow dropped. The sword must be fitted with a tassel.

(d) Broadsword

The apex of the broadsword shall not be lower than the top of the participant's ear when it is held erect in the hand, with the arm straightened and hanging down and the elbow dropped. The broadsword must be fitted with a ribbon.

(e) Nan Dao (Southern Broadsword)

The apex of the Nan Dao shall be above the chin level of the participant when it is

held erect in the hand, with the arm straightened and hanging down and the elbow dropped.



(a) Spear



(c) Sword



(d) Broadsword



(e) Nan Dao
(Southern
Broadsword)

- 21.7 Failure to comply with items 21.6(a) to 21.16e) will result in the deduction of **0.2** points.

SECTION C – AMENDMENTS AND MATTERS NOT PROVIDED FOR

24 ADJUSTMENT OF SCORES BY JURY, HEAD JUDGE/CHIEF REFEREE GROUP & TECHNICAL COMMITTEE

- 24.1 The Jury, Head judge/Chief referee group together with the Technical committee may adjust score by adding/subtracting up to a maximum of 0.2 points to the final score.
- 24.2 The Head judge will announce the final score once the adding/subtracting of the score has been endorsed by the Technical committee.

25 MATTERS NOT PROVIDED FOR

- 25.1 All matters not provided for in these Rules and Regulations shall be dealt with by the Wushu NSGOC.

26 AMENDMENTS

- 26.1 The Singapore Primary Schools Sports Council shall have the right to delete, add or amend the rules and regulations laid down herein.

List of Annexes

- A SPSSC Mission, Aspirations and Motto
- B NSGOC Terms of Reference
- C Age Dispensation
- D Management of Appeal for Late/ Erroneous Registration Workflow
- E 2005 IWUF Wushu Taolu Scoring System (Deduction Code)
- F Workflow for Appeal
- G Role of Team Managers
- H Guidelines for Appointing School Adult Representative (Parent) [SAR(P)]
- I Code of Conduct for Coaches

SINGAPORE PRIMARY SCHOOLS SPORTS COUNCIL (SPSSC)
AND SINGAPORE SCHOOLS SPORTS COUNCIL (SSSC)

Mission, Motto and Aspirations

Mission Statement

“To provide quality competition experience to our school athletes to support character development through the pursuit of sporting excellence”

Motto

“Character in Sporting Excellence”

Aspiration 1: *Every athlete an honourable sportsman*

Guiding Principle:

The athlete abides by the rules of the sport, gives his best in training and competitions, wins humbly and loses graciously. He participates actively and is committed to the skills development in his sport. He respects his opponents, teammates, coaches, teachers and officials, and displays exemplary conduct both on and off court.

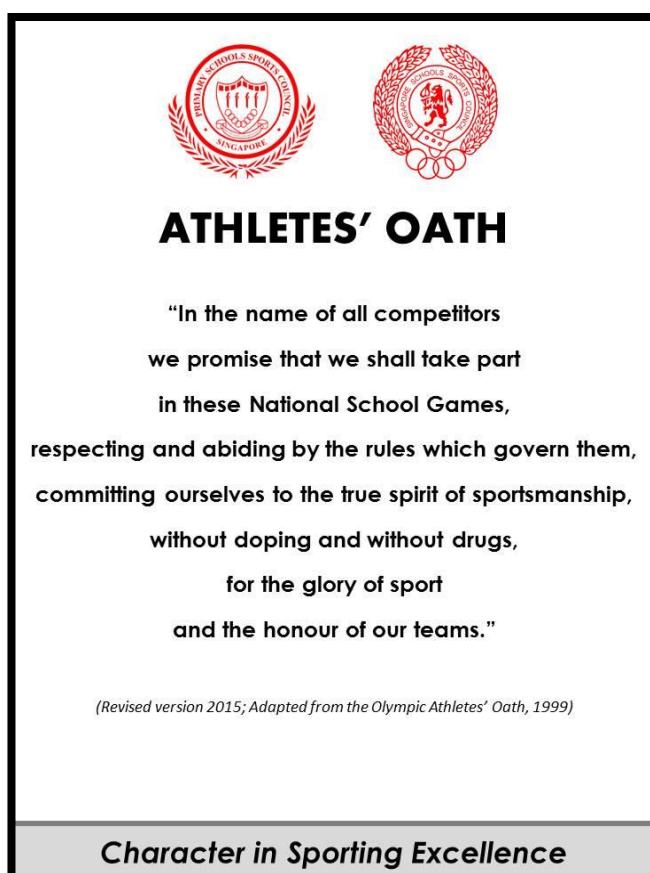

Aspiration 2: *Every teacher and coach an inspiring role model and mentor*

Guiding Principle:

The teacher/coach endeavours to develop each athlete to his fullest potential. He focuses on student-centric and values-driven coaching. He maintains a professional relationship with the athletes and ensures their safety and well-being at all times. As a positive role model, he inspires and motivates the athletes towards greater heights.



COACHES' OATH

*In the name of all the coaches,
we promise to respect all athletes,
officials and coaches in these
National School Games.*

*We shall act in the best interest of the
athletes and schools,
without doping and without drugs.*

*We commit ourselves to ensure that the
spirit of sportsmanship and fair play is
fully adhered to and upheld always."*

(Revised 2016; Adapted from the Olympic Coaches' Oath, 2012)

Character in Sporting Excellence

Aspiration 3: *Every official a fair, respectable and competent authority*

Guiding Principle:

The official is well-versed in the rules of the sport, and enforces the laws of the sport with impartiality. He is alert and acts decisively when required. He ensures safety for all athletes and explains the rules when required. He upholds the professionalism of the sport.

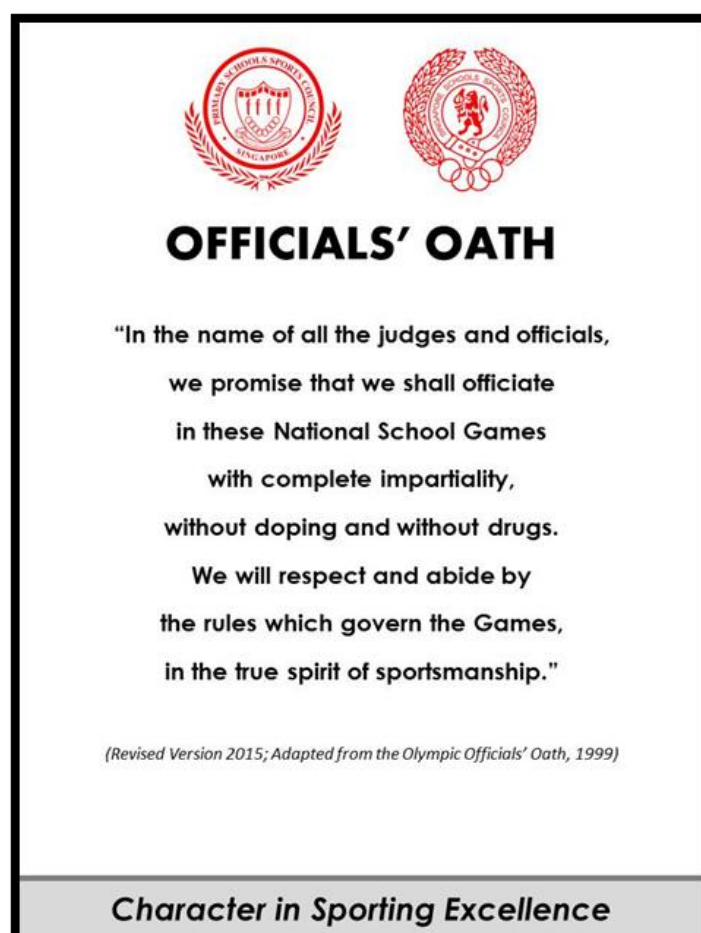

Aspiration 4: *Every parent a supportive partner*

Guiding Principle:

The parent takes interest in his child's training and competitions. He ensures proper nutrition and rest, and actively enquires on his child's progress and development. He works with the teacher and coach, attends competitions and respects the referee's decisions.

Aspiration 5: *Every spectator a respectful, responsible and caring motivator*

Guiding Principle:

The spectator makes the effort to applaud excellence and fair play. The spectator shows appreciation for the efforts of all athletes, teachers, coaches, officials and organisers. He should cheer to encourage and motivate as well as care for the athletes' well-being. The parent takes interest in his child's training and competitions. He is responsible and keeps the venue safe and comfortable for all.



SPECTATORS' CREED

Be a Respectful Supporter

- Applaud excellence and fair play
- Appreciate the efforts of all athletes, teachers, coaches, officials and organisers

Be a Caring Motivator

- Cheer to encourage and motivate
- Care for athletes' well-being

Be a Responsible Spectator

- Keep the venue safe and comfortable for all
- Keep the venue clean

Character in Sporting Excellence

Aspiration 6: *Every game a safe and enriching learning experience*

Guiding Principle:

The format of competition is developmental and age-appropriate. The games provide athletes with the opportunity to display their sporting prowess, and be recognised for their achievements. Athletes enjoy the competitions, which are conducted under safe and conducive environments.

**TERMS OF REFERENCE FOR SPSSC/SSSC
NATIONAL SCHOOL GAMES ORGANISING COMMITTEES (NSGOCs)**

The NSGOCs shall have sub-committees to ensure the successful organising and completion of their respective sports that includes but is not limited to the following functions:

1. TECHNICAL

- a. Establish competition rules and regulations for the sport to ensure age appropriateness and opportunities for skills development, including, but not restricted to:
 - Age grouping / division
 - Format of competition
 - Permitted equipment
 - Field of play
 - Duration of play; intervals
 - Number of participants
 - Substitution rules, etc.
- b. Identify and appoint the technical director and officials for each competition.
- c. Monitor and review baseline safety standards for the competition.
- d. Review and update competition rules and regulations annually and submit Games Recommendations to National School Games Organising Committee or Council Standing Committee for approval, where appropriate.

2. COMPETITION

Organise the competition according to the rules and regulations, and established safety standards, including:

- a. Planning and Execution:
 - i. Work out the competition schedules, fixtures and venues required.
 - ii. Communicate with participating teams on all competition matters, including, but not limited to: rules, dates, fixtures, venue, etc.
 - iii. Identify and appoint Competition Director (if applicable) for deployment of officials.
 - iv. Manage competition officials, venues, equipment, medical cover and logistics for effective and efficient conduct of the competition.
- b. Risk Assessment and Management:
 - i. Carry out risk assessment and management planning for each venue, including adherence to the baseline safety standards.
 - ii. Communicate relevant parts of the risk assessment and management plan to all relevant parties.
 - iii. Monitor and manage safety and security issues at the competition venue.
- c. Venue Management:
 - i. Ensure competition venues (including hosting schools) have the following in good condition to support the competition:

- Equipment
 - Line Drawings (if applicable)
 - Consumables
 - ii. Inform Hosting Schools of competition schedule.
 - iii. Disseminate competition fixtures to all Hosting and Participating Schools once fixtures are confirmed.
 - iv. Inform Hosting and Participating Schools at least three (3) working days before should there be any changes in venue or fixtures.
 - v. Ensure that technical officials and medical support (if applicable) arrive at stipulated time at the competition venue.
 - vi. Remind Team Managers at school briefing:
 - i. To check the latest Info Pack of the Hosting Schools in NIS before each match day
 - ii. To inform their fellow colleagues who may be accompanying their students for the competitions on their behalf
 - vii. Prepare the competition venue, such as display of PDPA notifications, proper allocation of spaces for assembly, warm-up, match, rest areas, spectators, where appropriate.
- d. Results Processing:
- i. Ensure competition results are promptly and accurately sent to the NSGO for uploading to the NSG website.
- e. Protest Management:
- i. Respond to query(ies)/protest(s) by participating school(s) during the competition.
 - ii. Conduct investigations and resolve the query(ies)/protest(s) relating to the competition.

3. RECOGNITION, APPEAL AND DISCIPLINE

- a. Recognition
- i. Develop and implement appropriate recognition (including recognition criteria), to support the desired outcomes of the National School Games, such as Sportsmanship Award.
 - ii. Collect and communicate good stories to relevant party(ies), including participating schools, MOE HQ and the media where appropriate.
 - iii. Plan and organise prize-giving ceremonies for the competition.
- b. Appeal
- i. Work with Competition and Technical Sub-Committees to conduct investigations with all parties involved, in consultation with the Games Advisor and Vice-Chairman of the Standing Committee where relevant.
 - ii. Resolve all appeals and respond to relevant party(ies) on the outcome within a week of incident reported.
 - iii. Update SPSSC/SSSC Standing Committee on the outcome of the queries / protests / appeals, where warranted.

c. Discipline

- i. Work with Competition and Technical Sub-Committees to conduct investigations pertaining to disciplinary case(es) with all parties involved, in consultation with the Games Advisor.
- ii. Resolve all disciplinary case(es) and respond to relevant party(ies) on the outcome within a week of the case(es).
- iii. Develop disciplinary policies and systemise processes to manage student(s), teacher(s), coach(es) and umpire(s) for alignment to the Councils' mission, motto and aspirations.

AGE DISPENSATION FOR SPSSC

1. BACKGROUND

Age Dispensation refers to the approval for a student to participate in a sport recognised by the Singapore Primary Schools Sports Council (SPSSC).

This **only** applies to 7 and 8 years old who wish to participate in the 'Junior' Division competitions organised under the auspices of the SPSSC (except the 5 identified sports⁵ with higher risks). Poomsae event for Taekwondo is allowed.

2. APPLICATION PROCESS

Eligible students (listed in para 1) are to apply for age dispensation with their respective NSGOC using the application form in Annex D2. This form has to be submitted by their parents/guardians and endorsed by their school Principal.

The application form has to be submitted together with the school's registration for the competition.

Any application submitted after the closing date stipulated by the respective NSGOC will not be considered.

3. TERMS AND CONDITIONS

a. Age dispensation for 7 and 8 years old is only allowed for the following sports:

- | | |
|------------------|------------------------|
| a) Badminton | g) Swimming |
| b) Bowling | h) Table Tennis |
| c) Golf | i) Taekwondo (Poomsae) |
| d) Gymnastics | j) Tennis |
| e) Rope Skipping | k) Track and Field |
| f) Sailing | l) Wushu |

b. Age dispensation is only granted for the year of application.

c. Once approved, the student can only compete in the applicable division as stated in the specific sport rules and regulation, i.e. for both individual and team events for the approved year.

⁵ The 5 identified sports are Rugby, Football, Basketball, Hockey and Taekwondo (Kyrugi). Taekwondo (Poomsae) is a non-contact segment, hence it is not classified as a sport with higher risk.

SPSSC FIVE STEP FLOWCHART FOR AGE DISPENSATION

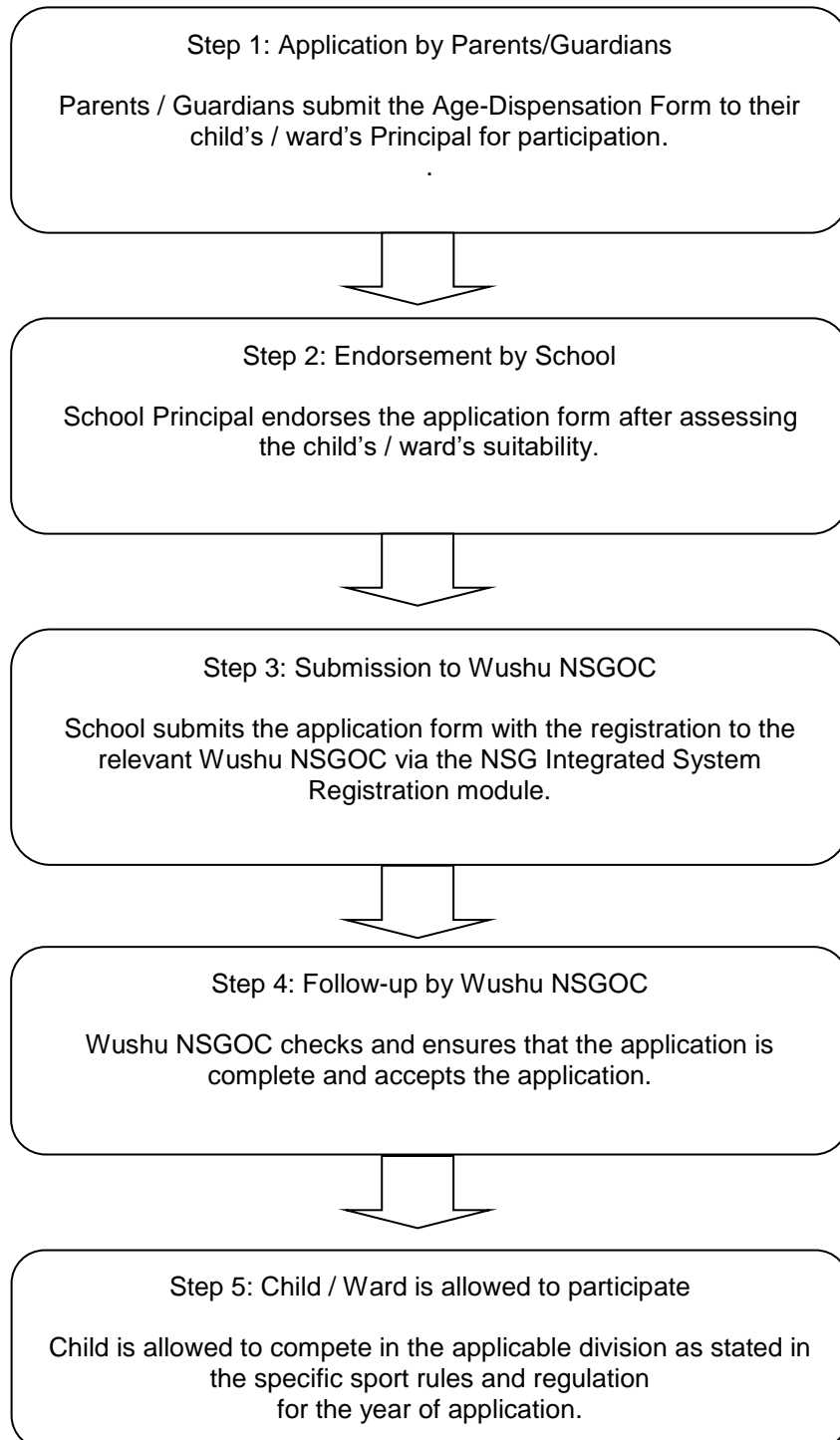

**SINGAPORE PRIMARY SCHOOLS SPORTS COUNCIL
APPLICATION FOR AGE DISPENSATION**

Sport:			
Student's Particulars			
Name:		Gender:	
NRIC:		Date of Birth:	
Parent's / Guardian's Particulars			
Name:		* Father/Mother/Guardian	
Contact Number		Alt Contact Number:	
School's Particulars			
School:			
Principal:			
Teacher in charge:			
Contact Number		Alt Contact Number:	
Rationale Supporting the Request for Age Dispensation			

Acknowledgement by Parent/Guardian:

I, _____, parent/guardian of _____ would like to request for my child/ward to represent the school in the SPSSC competition for the above-mentioned sport in _____ (Year).

I have assessed his/her physical and mental readiness and deem him/her to be suitable and ready to compete in the above-stated category.

Parent's/Guardian's Signature and Date

Principal's Endorsement:

Principal's Signature and Date

Management of Appeal for Late/Erroneous Registration Workflow

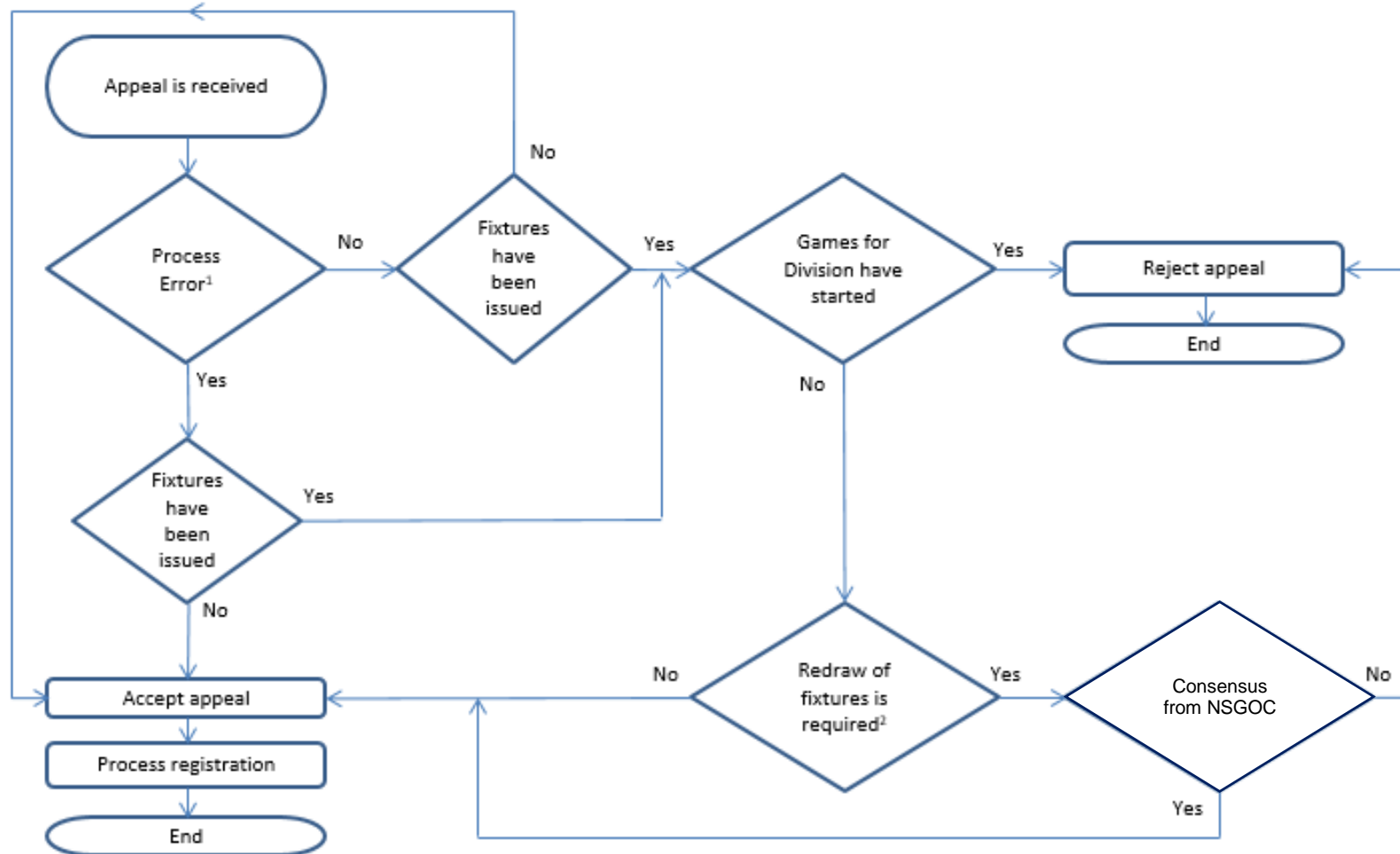

Note:

¹: Refers to errors such as technical glitches, miscommunication by Organiser, erroneous information by Organiser, etc.

²: Required if (i) appellant is a seeded team, (ii) there is change in format/number of groups

国际武术套路竞赛规则



国际武术联合会审定

2005年11月

第一章 自选项目的评判

第一节 动作质量的评分

一、自选项目动作规格错误内容及扣分标准

(一) 自选长拳、剑术、刀术、枪术、棍术动作规格错误内容及扣分标准 (表 1-1)

类别	动作	扣分内容	一级 编码	二级 编码
平衡	搬脚朝天 (侧踢抱脚、侧朝天蹬) 直立	▼支撑腿弯曲▼上举腿弯曲	1	10
	后踢抱脚直立	▼支撑腿弯曲▼上体前倾超过 45 度		11
	仰身平衡	▼前举腿低于水平		12
	十字平衡	▼躯干低于水平		13
	扣腿平衡	▼支撑腿大腿未接近水平		14
腿法	前扫腿	▼支撑腿大腿高于水平▼扫转腿脚掌离地▼扫转腿弯曲	2	20
	后扫腿	▼扫转腿脚掌离地▼扫转腿弯曲		21
	跌叉	▼竖叉前脚内扣触地▼两腿未成一直线		22
	弹腿、踹腿	▼未由屈到伸		23
跳跃	腾空飞脚、旋风脚、腾空摆莲	▼击响腿脚尖未过肩▼击拍落空	3	30
	腾空正踢腿	▼悬垂腿弯曲		31
	侧空翻、侧空翻转体 360 度	▼空中腿明显弯曲		32
	旋子、旋子转体	▼转体时上体高于水平 45 度▼空中腿明显弯曲		33
	腾空箭弹	▼起跳腿未由屈到伸弹出▼弹出腿低于水平		34
步型	弓步	▼前腿膝部未达脚背▼屈蹲腿未达水平▼后脚跟离地 ▼后脚尖未内扣	5	50
	马步	▼上体明显前倾▼屈蹲腿未达水平▼两脚间距过小 ▼脚跟离地▼脚尖外展		51
	虚步	▼屈蹲腿未达水平▼屈蹲腿脚跟离地		52
	仆步	▼屈蹲腿未全蹲▼仆腿未伸直▼仆腿全脚掌未内扣着地		53
器械 方法	挂剑、撩剑	▼直腕	6	60
	摆剑	▼食指扣摆剑在剑盘前沿触及剑刃		61
	缠头裹脑	▼刀背远离身体		62
	拦枪、拿枪	▼枪尖未划弧		63
	扎枪	▼后手留把		64
	立舞花枪、立舞花棍、双手提擦花棍	▼未立圆		65
	器械抛接	▼抱接器械▼未单手接握剑柄、刀柄、棍身、枪身		66

注：1、在一个动作中出现两个以上动作规格错误，均一次性扣 0.1 分。

2、在一组动作中出现两个以上器械方法错误，均一次性扣 0.1 分。

3、凡平衡动作必须出现静止状态；持久平衡静止时间不得少于 2 秒。

(二) 自选太极拳、太极剑动作规格错误内容及扣分标准 (表 1-2)

类别	动作	扣分内容	一级 编码	二级 编码
平衡	前举腿低势平衡	▼前举腿低于水平	1	15
	后插腿低势平衡	▼插出腿脚触地		16
	低势前蹬踩脚	▼支撑腿脚跟离地▼前蹬踩前腿膝部弯曲▼脚尖未外展		17
	侧踹平衡	▼踹腿未由曲到伸		18
腿法	分脚、蹬脚	▼上举腿低于水平▼上举腿未伸直	2	24
	摆莲脚	▼击响时摆动腿弯曲▼击拍落空		25
	拍脚	▼击响时摆动腿弯曲▼击拍落空		26
	雀地龙	▼前脚掌内扣触地▼两大腿夹角小于 45 度		27
跳跃	腾空飞脚、旋风脚、腾空摆莲	▼击响腿脚尖未过肩▼击拍落空	3	30
	腾空正踢腿	▼悬垂腿弯曲		31
步型 步法	弓步	▼前腿膝部未达脚背▼后脚跟离地	5	50
	仆步	▼屈腿未全蹲▼仆腿未伸直▼仆腿全脚掌未内扣着地		53
	上步、退步、进步、跟步、侧行步	▼脚拖地 (特殊动作要求除外)▼移动时重心起伏▼抬脚过高		54
器械 方法	挂剑、撩剑	▼直腕	6	60
	摆剑	▼食指扣摆剑在剑盘前沿触及剑刃		61

注：1、在一个动作中出现两个以上动作规格错误，均一次性扣 0.1 分。

2、在一组动作中出现两个以上步法与器械方法错误，均一次性扣 0.1 分。

(三) 自选南拳、南刀、南棍动作规格错误内容及扣分标准 (表 1-3)

类别	动作	扣分内容	一级 编码	二级 编码
腿法	前扫腿	▼支撑腿大腿高于水平▼扫转腿脚掌离地▼扫转腿弯曲	2	22
	横钉腿	▼钉腿直摆▼未横向异侧钉击		28
跳跃	腾空飞脚、旋风脚、腾空外摆腿	▼击响腿或摆动腿脚尖未过肩▼腾空飞脚、旋风脚击拍落空	3	30
跌扑	腾空盘腿 360 度侧扑	▼摆动腿脚未过头	4	40
	鲤鱼打挺直立	▼手撑扶地面		41
	腾空双侧踹	▼踹出腿未并拢▼踹出腿弯曲		42
步型	弓步	▼屈腿未接近半蹲▼后脚跟离地	5	50
	马步	▼上体明显前倾▼屈腿未接近半蹲▼屈腿低于水平 ▼两脚间距过小▼脚跟离地		51
	虚步	▼屈腿脚跟离地▼屈腿未接近半蹲		52
	仆步	▼屈腿未全蹲▼仆腿未伸直▼仆腿全脚掌未内扣着地		53
	蝶步	▼跪地腿小腿内侧未着地▼跪地腿脚跟内侧未着地		55
	跪步	▼下跪腿膝部着地▼臀部未坐在下跪腿小腿上		56
	骑龙步	▼后腿膝部着地▼前腿未接近半蹲		57
器械 方法	缠头裹脑	▼刀背远离身体	6	62
	顶棍	▼把端未柱地▼梢端低于头		67

注：1、在一个动作中出现两个以上动作规格错误，均一次性扣 0.1 分。

2、在一组动作中出现两个以上器械方法错误，均一次性扣 0.1 分。

二、自选项目和无难度要求项目（单项）其他错误内容及扣分标准

（一）其他错误内容及扣分标准（表 1-4）

类别	扣分内容	编码
失去平衡错误	上体晃动、脚移动或跳动	70
	附加支撑（扣 0.2 分）	71
	倒地（扣 0.3 分）	72
器械服饰错误	器械触地、脱把、碰身、变形	73
	器械折断（扣 0.2 分）	74
	器械掉地（扣 0.3 分）	75
	刀形、剑穗、枪缨、服饰、头饰掉地；刀形、剑穗、软器械缠手（缠身）；服装开纽或撕裂；鞋脱落	76
其他错误	持久平衡静止时间不足 2 秒	77
	身体任何一部分触及场外地面	78
	遗忘	79

注：1、晃动：是指双脚或单脚支撑时，上体出现的双向位移。

2、移动：是指双脚或单脚或一脚一腿支撑时，任何一脚出现的位移。

3、附加支撑：是指由于失去平衡造成手、肘、膝、头部、上臂、非支撑脚触地或借助器械撑地。

4、倒地：是指双手、肩、躯干、臀部触地。

5、持久平衡静止时间：以首次出现静止状态开始计时。

6、器械接触场外地面或身体某一部分在空间超越了场地，不应判为出界。

7、未标明扣分值均为扣 0.1 分。

8、在一个动作中连续出现两个以上其他错误，应累计扣分。

第二章 无难度要求项目的评判

第一节 动作质量的评分

单练项目按照自选项目动作规格错误内容及扣分标准（表 1-1、表 1-2、表 1-3）和自选项目及无难度要求项目（单项）其他错误内容及扣分标准（表 1-4）执行。

第二节 演练水平的评分

一、无难度要求项目演练水平等级分评分标准和编排错误扣分标准（表 5）

等级分评分标准			编排		
档次	级别	分数段		扣分内容	编码
好	①级	5.00--4.81	内容	各项目规定套路中漏做或增加一个完整动作（扣 0.2 分）	80
	②级	4.80--4.51		规定南拳、南刀、南棍套路中未按规定发声	81
	③级	4.50--4.21	结构布局	各项目规定套路中跳跃动作的助跑步数或行进动作的步数缺少或增加	82
④级	4.20--3.81				
⑤级	3.80--3.41				
⑥级	3.40--3.01	太极拳、太极剑动作路线和方向超过 45 度；长拳、南拳及器械超过 90 度	83		
不好	⑦级	3.00--2.51	音乐	出现有伴唱配乐（扣 0.3 分）	84
	⑧级	2.50--2.01			
	⑨级	2.00--1.51		规程规定配乐的项目无配乐（扣 0.5 分）	85

注：编排错误扣分内容中，未标明扣分值均为扣 0.1 分。

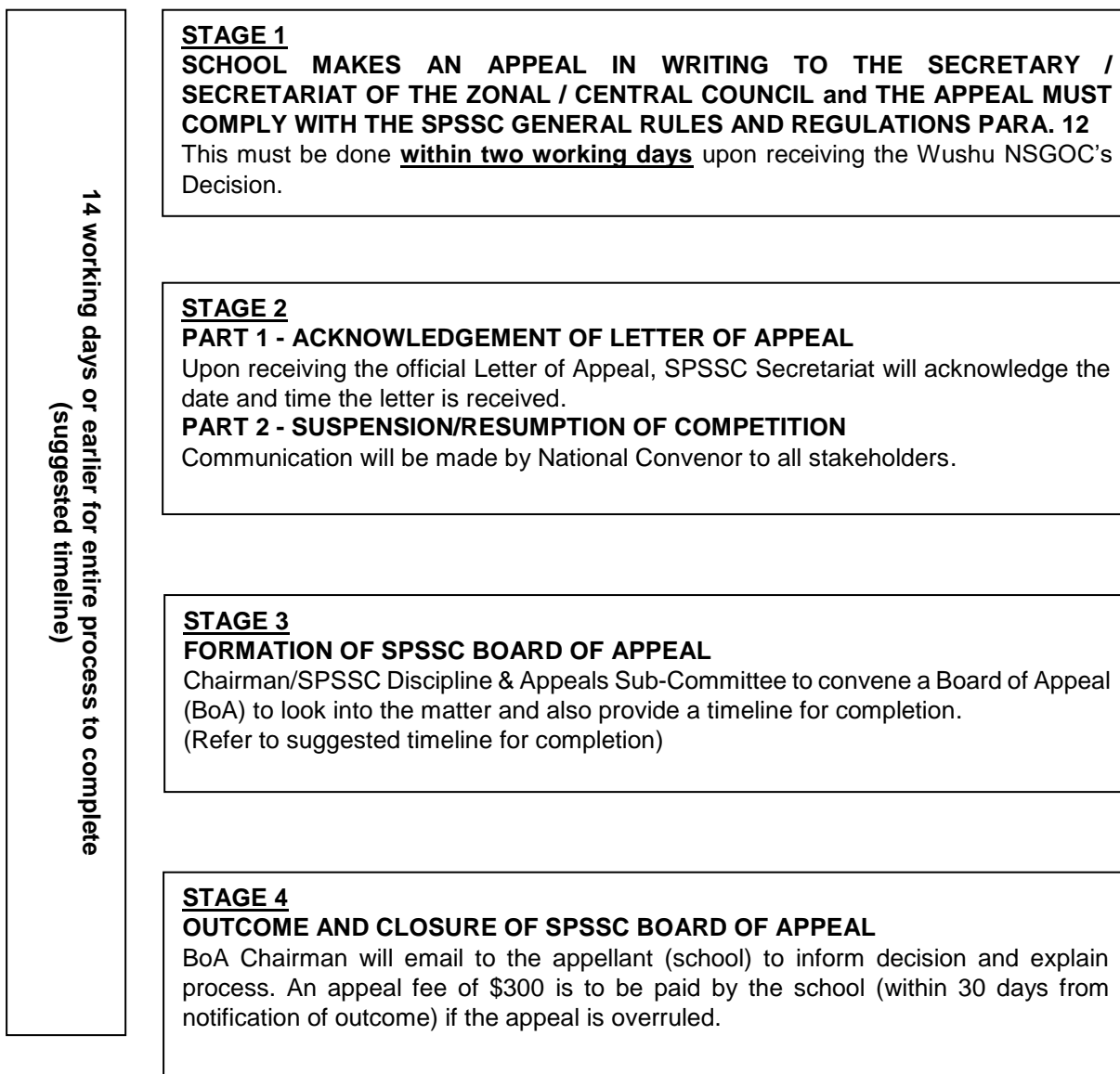
SPSSC WORKFLOW FOR APPEALS

As in accordance with the SPSSC General Rules and Regulations under rule 13.4, the decision of the Board of Appeal or the Standing Committee shall be final.

SINGAPORE PRIMARY SCHOOLS SPORTS COUNCIL

Role of The Team Manager

The team manager (TM) will represent the school on all matters pertaining to the duty of care, student management and competition matters relating to the participants from his / her school. He/she must be a good role model for the participants and are expected to conduct themselves well in carrying out their duties. He/she will do the following:

	Terms of Reference
1	Point of contact between the National School Games Organising Committee (NSGOC) and the Principal (school).
2	Attend all briefings and/or meetings called for by the respective NSGOCs.
3	Check & verify the fixtures and schedules involving the school.
4	Ensure the accuracy of participants' particulars in the registration and that students are not placed in the wrong division.
5	Make transport arrangements for the participant(s).
6	To chaperone participant(s) to and from the competition venue and remain with the participant(s) throughout the duration of play.
7	Cooperate with NSGOC & officials and abide by the rules and regulations of the competition.
8	Submit team list & other necessary documents when required to.
9	Manage the coach, participant(s) and supporter(s), if any, to ensure that they adhere to the Code of Conduct as provided in SPSSC Rules & Regulations.
10	Arrange for a replacement, in the event that he/she is not able to perform his/her duty, including when it is halfway through the competition
11	Duty of care for the participant(s) safety and well-being and to ensure that the participant(s) is/are medically covered e.g. first aid kit.
12	Contact the school immediately in the event of an injury or emergency.
13	Do not speak to the media unless with permission from the school
14	Represent the school in matters pertaining to formal appeals/protests (as required by the sport)
15	Accompany participant(s) at disciplinary board meetings if the occasion arises.
16	Any other matters pertaining to the duty of care, student management and competition matters relating to the participants from his / her school.

Flow Chart for appointing School Adult Representative (Parent) [SAR(P)]**To take note of:****Step 1: Appoint SAR(P)**

School Principal shall assess the suitability of the parent of participating student athlete before appointing him/her as the SAR(P).

- Only Legal Guardian/parent of one of the student athletes is allowed to be appointed

**Step 2: Brief SAR(P) & Sign Letter of Agreement**

School shall conduct a briefing for the newly appointed SAR(P) on the following documents:

- Terms and Conditions
- Roles and Responsibilities

Upon agreeing to all the terms stated, the SAR(P) will be required to sign the Letter of Agreement.

- SAR(P) must be briefed by participating school
- School to brief SAR(P) of the safety and intervention measures using the RAMS Form.

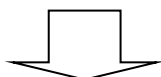
**Step 3: Issue Appointment Letter**

School issues Appointment Letter to SAR(P).

- School to clearly indicate the start and end dates of the SAR(P)'s duty on the letter

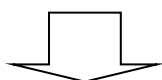
**Step 4: e-Registration**

School registers the student athlete(s) and SAR(P) via the NIS Registration Module.

- School Coordinator login to the NIS Registration Module to register themselves as "Team Manager" and upload BSS School Acknowledgement Form
- School Coordinator registers SAR(P) and uploads Appointment

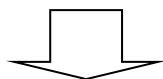
**Step 5: Sign-in at the Competition Venue**

SAR(P) signs in the student athlete(s) and ensures that the student athlete(s) adheres to the respective game's rules and regulations at all times.

- SAR(P) to provide a photo identification for verification when on the day of competition

Code of Conduct for Coaches

- 1) Coaches must be good role models for the student athletes and are expected to conduct themselves well in carrying out their duties.
- 2) They are to observe the rules and regulations of the National School Games and honour the Coaches' Oath.
- 3) They should not replace the role of the team manager.
- 4) They are to prepare the training schedule for the team, in consultation with the Principal and the teacher in-charge (i.e. 30-week programme)
- 5) They are not allowed into the competition area except where the rule of the sport requires the presence of the coach e.g. Softball and Gymnastics.
- 6) They cannot represent the school in any matters.
- 7) They must not interfere with the organisation of the competition.
- 8) They are not allowed to approach the officials to query their decisions. Only team managers are allowed to approach officials to seek clarifications.
- 9) Coaches violating the rules will be asked to leave the competition arena.
- 10) Action will be taken against the school if the coaches fail to comply with the competition rules.
- 11) It is the responsibility of coaches to adhere to the rules and to be well versed with the competition rules.
- 12) They must ensure that the student athletes have adequate rest and are given water breaks.
- 13) Coaches should refrain from using foul language or speak in a tone not becoming of proper behaviour.