



National Schools Games Floorball Competition Junior 2022 Competition Rules and Regulations

This document outlines the rules and regulations for the conduct of and participation in the National School Games (NSG) 2022. This is subject to possible changes in prevailing national posture. Updates will be communicated to participating schools when required.

SECTION A – ADMINISTRATIVE RULES & REGULATIONS

1 ORGANISATION STRUCTURE AND GOVERNING BODIES

1.1 The National School Games (NSG) shall be conducted:

- 1.1.1. as governed by the General Rules and Regulations of the Singapore Primary Schools Sports Council (SPSSC).
- 1.1.2. according to the laws/rules established by the respective International Federations (IFs)/governing bodies.
- 1.1.3. adhering to the Baseline Safety Standards for the NSG.
- 1.1.4. In the event that the rules and regulations are modified for safety/developmental reasons to suit the level of our school students, it must be clearly stated in the respective sports rules and regulations.
- 1.1.5. In the absence of a set of recognised rules to govern the occurrence of situations during the competitions, the respective National School Games Organising Committee shall make the final decision.

1.2. NATIONAL SCHOOL GAMES ORGANISING COMMITTEE (NSGOC)

1.2.1. The NSGOC shall consist of the following:

- a) The National Convenor,
- b) The Game Advisor,
- c) The Zonal Convenors,
- d) Organising Secretaries and
- e) Any other co-opted members deemed necessary

1.2.2. The NSGOCs are empowered to appoint sub-committees and individual members to assist in the organisation and running of the NSG competitions as and when required.

1.2.3. The NSGOCs shall have sub-committees to perform the following roles and responsibilities (**Ref Annex B**): -

- a) Technical: Establish, review and update competition rules and regulations for the competitions and other matters necessary to provide for developmentally appropriate NSG competitions.
- b) Competitions: Organise and conduct the competition according to the rules and regulations, and established safety standards.
- c) Recognition, Appeal and Discipline: Manage recognition and discipline structures to support the desired outcomes of the NSG.
- d) Other functions necessary for the successful completion of the NSG sport that the NSGOC is in charge of.

2 AGE GROUP / DIVISIONS

2.1 All students shall compete in their respective divisions according to their year of birth.

Division	Year/Date of Birth
Junior Division	1 Jan 2014 1 Jan 2013 --- 31 Dec 2013 1 Jan 2012 --- 31 Dec 2012 2 Jan 2011 --- 31 Dec 2011 1 Jan 2011 (<i>subject to conditions laid out in para 2.2</i>)

2.2 All students shall compete in the respective divisions set out in the R & R (Annex C) **with the exception of those born on 1 January who have been given approval for deferment by MOE during P1 registration.** These students will compete in the division with the cohort that they are studying with.

2.2.1 With effect from 2021, students who are born on 1 January and have participated in NSG previously shall follow the rules stated in Para 2.2. This rule will supersede all previous decisions.

2.2.2 This exception in Para 2.2 does not apply to students who are born on 1 January and have repeated a year of study.

2.3 All students can only compete in one division of that particular sport within the same year.

2.4 Age dispensation is **NOT** applicable to Floorball.

3 ENTRIES

3.1 Each school's team **MUST** consist of 2 sub teams.

Boys Junior Division	<ul style="list-style-type: none"> • Max no. to register: 18 participants (2 sub-teams of 9 players)
Girls Junior Division	<ul style="list-style-type: none"> • Min. no. to register: 8 participants (2 sub-teams of 4 players)

- 3.2 All entries must be submitted through the Registration Module at <https://nsg.moe.edu.sg/nis/#!/login> on or before the stipulated closing date. This includes details of participants along with the necessary supporting documents.
- e) Baseline Safety Standards Acknowledgement Form
 - f) Supporting documents for Special/Transfer case students
 - g) Other forms as determined by the respective NSGOCs
- 3.3 Appeals for late/ erroneous entries¹ submitted by schools will be accepted on a case-by-case basis with consensus from the Organising Committee. (**Ref Annex D**).
- 3.3.1 Schools must write in through the Principal, to inform the Convenors of any appeal at least one (1) working day before the next match.

4 REGISTRATION OF PARTICIPANTS

4.1 Registration of Participants (Junior Division)

4.1.1 Schools participating in the competition shall be entitled to register a maximum of 18 participants for the competition. Minimum number of participants to be registered is 8 participants. **No other than those mentioned on the registered list are allowed to be in the substitution zone or team bench during each match.**

4.2 If a school chooses not to register the maximum number of participants allowed by the sport at the time of registration, the school shall not be permitted to register additional participants subsequently.

4.3 Only in the event that any participant(s) registered is/are transferred or has/have to leave school during the preliminary rounds, the school shall be allowed to replace the affected participant(s).

4.3.1 Schools must write in to inform the Convenors of the replacement at least one (1) working day before the next match.

4.3.2 No replacement of participants is allowed once the competition reaches the semi-final stage or after two (2) games have been played in a single group round league.

4.4 International students can only be registered to play for their school **after** they have been issued with the student passes from the Immigration and Checkpoints Authority (ICA).

4.5 International students who are in the schools on exchange programme are not allowed to represent the school.

4.6 Students granted Leave of Absence (LOA) by MOE will be allowed to represent the school.

4.7 Registration constitutes representation, that is, once a student is registered to play for a school, he or she is deemed to have represented his or her school. Hence, the student is not allowed to represent another school in the same sport in the same year.

¹ The rule applies to late/ erroneous in entries and registration of participants.

4.8 Failure to comply with rules 4.1 to 4.7 shall lead to the disqualification of the team.

SECTION B – COMPETITION RULES & REGULATIONS

5 COMPETITION FORMAT

- 5.1 For Team Sports, there must be a minimum of **three (3)** registered teams from **three (3)** different schools before a team competition can be organised.
- 5.2 Each school shall send 2 sub teams for the competition as stated in para 3.1.
- 5.3 The competition format shall be that as approved by the SPSSC's Standing committee and stated in the specific sport's rules and regulations.
- 5.4 The competition at the Classification Round shall be organized on an inter-school league. Where entries are grouped, each classification group shall have a **minimum of four (4) teams**.
- 5.5 For tiered competitions, a classification round will be used to determine the tier that the team/participant(s) will be playing in based on their competency. In the tiered round, each tier will be treated as a separate competition and the results in each tier shall be independent of the results in the other tiers.
- 5.6 The top two (2) teams from each classification round group will qualify for Tier 1. The remaining teams will qualify for Tier 2 or Tier 3 depending on the number of participating teams. Both phases will be run in a round robin format.
- 5.7 Any deviation from the competition format requires approval from the SPSSC Council or the Standing Committee and must be clearly stated in the respective sports rules and regulations.

6 AWARD OF LEAGUE POINTS

- 6.1 All schools will play against each other in the Classification and Tier group and the following points will be awarded for each match:
 - Win 3 points (to winning sub team)
 - Draw 1 point (to each sub team)
 - Loss/ Walkover 0 point (to losing sub team/ sub team conceding a walkover)
- 6.2 In the case of a **two-schools tie**, the positions shall be established by the following sequence:
 - The winner of the match between the two schools concerned shall be awarded the higher placing (Head-to-head)
 - Followed by Goal Difference (schools in the group)
 - Followed by Goals Scored (schools in the group)
- 6.3 If **more than two schools** have equal league points, the positions shall be established by the following sequence:

- Goal Difference (i.e., of matches played only among the tied schools).
- Followed by Goals Scored (i.e., of matches played only among the tied schools).

*Should there be the case of the tie not being broken; the 2 or more schools concerned will play a penalty shoot-out to determine the positions. Refer to Para 6.4 for penalty shootout details.

6.4 A penalty shootout of 3 penalty shots will decide the winner if the match ends in a draw in the knock-out phase of the competition. If a tie should result at the end of 3 penalty shots, the shootout will automatically go into sudden death. A different participant in turn from the same 3 penalty shot takers but, in any order, would have to take each sudden death penalty until a winner is determined.

7 PRIZES

7.1 Where there are tiered competitions, up to the top 40% of participants / teams of each tier can be awarded with medals.

7.2 Within each tier, the absolute number of medals awarded within each group should be the same.

7.3 The form of the medals awarded shall be as follows:

Position	Form of Medals
1 st	Gold
2 nd	Silver
3 rd	Bronze
4 th	Bronze
5 th to 8 th	Bronze

7.4 Achievement Pins

7.4.1 Achievement pins can be awarded up to 50% of participants for the rest of the sports.

8 REPORTING AND GRACE PERIOD

8.1 Fifteen minutes (15 min) grace is allowed. The Convenor or his/her representative may at his/her discretion extend this grace period if he/she thinks the extension of grace period is justifiable (e.g., in special cases when delay may be caused by traffic jams, etc). However, the team concerned must contact the Convenor or his/her

representative at the venue concerned to inform him/her of the delay. Teams must abide by the decision of the Convenor or his/her representative.

9 POSTPONEMENT

- 9.1 The Convenor or his/her representative shall, at his/her discretion, decide to postpone a match if it thinks the venue is unfit for play, or for any other valid reasons for which it deems a postponement is in order. Teams must abide by the decision of the Convenor or his/her representative.

10 WITHDRAWAL OR WALK-OVER

- 10.1 Any withdrawal or walkover is considered to be contrary to the spirit of the sport.
- 10.2 Schools participating in the NSG should not withdraw or concede a walk-over without a valid reason.
- 10.3 The walkover score line will be 5 – 0 in favour of the team that is present.
- 10.4 For each withdrawal² or walk-over, a written explanation duly endorsed by the Principal shall be submitted to the Convenor and the Game Advisor within two (2) working days.
- 10.5 In the play-off for top 4 placing, any walkover will disqualify the team from being placed.

11 ABANDONED GAME

- 11.1 The referee/umpire and venue manager are required to submit a written report on an abandoned game within one (1) working day to the NSGOC.
- 11.2 For decision on abandoned game, refer to Para 20 on disqualifications.

12 PROTEST

Any clarification on points of laws/rules, must be lodged immediately by the Team Manager (TM) to the referee / umpire / judge. Any decision made by the referee / umpire / judge will be final.

- 12.2 All protests shall be referred to the NSGOC. The protest(s) must reach the Committee within **one (1)** working day following the match to which it relates unless stipulated otherwise in the respective sport's rules. The protest must be in writing and duly signed by the principal. A protest fee of \$150 is to be paid by the school (within 30 days from notification of outcome) if the protest is overruled.

- 12.3 The NSGOC will deliberate on the protest within five (5) working days. The decision will then be made known in writing to the school concerned.

- 12.4 When there is any conflict of interest, the school(s) involved will not sit in the committee considering the protest.

² All results involving the team will be null and void.

13 APPEAL (Ref Annex G)

Upon the release/disclosure of the decision of the NSGOC, only schools may appeal to the Council.

13.2 Notices of appeal shall be lodged with the Secretary / Secretariat of the Zonal / Central Council within two (2) working days upon receiving the NSGOC's decision. The appeal must be in writing and duly signed by the Principal or via email sent by the Principal.

13.3 An appeal fee of \$300 is to be paid by the school (within 30 days from notification of outcome) if the appeal is overruled.

13.4 The Board of Appeal will deliberate on the appeal. The decision of the Board of Appeal shall be final.

14 SUSPENSION

Participant(s) suspended by any one of the following bodies is barred from participating in the NSG for that sport for the period of suspension:

- a) The School
- b) The Zonal Council
- c) The Singapore Primary Schools Sports Council (SPSSC)
- d) The National Sports Association (NSA) of the sport

15 TEAM MANAGER (TM)

15.1 Each participating team must be accompanied by a TM who shall remain with the team throughout the duration of play (Please refer to **Annex H**).

15.2 The TM shall be a teacher appointed by the participating school.

15.3 The TM must check and comply with the hosting school's Standard Operating Procedures (SOPs) and communicate all the information to all stakeholders associated with the participating school.

15.4 TMs are expected to conduct themselves with decorum during competitions.

15.5 TMs are not allowed to interfere with the final decision taken by the referee/umpire/judge/official on points of laws/rules after clarification has been sought. If such interference results in disruption of any match, a report shall be made by the Convenor and the matter brought to the attention of the NSGOC for appropriate action.

16 REFEREE/ UMPIRE / JUDGE / OFFICIAL / PITCH or COURT MANAGERS

- 16.1 The Vendor shall provide referee/(s) and venue manager/(s) for all the matches. All referees and court managers need to be qualified Singapore Floorball Association referees/match secretaries.
- 16.2 The Venue Manager will be provided by the Vendor and act as the match secretary for all matches.
- 16.3 The Venue Manager will oversee timekeeping for actual match, bench/match penalty and update score. He/she will complete and submit the match record form to the NSGO Executive at the end of each match day. He/she will also update the NSGO Executive with the summary of all scores for updating on the SPSSC website.

17 COACHES

- 17.1 Coaches are expected to conduct themselves with decorum during competitions and in alignment to the code of conduct (**Ref Annex A**) and spirit of the Coaches Oath (**Ref Annex A**) during competitions.
- 17.2 Coaches are not allowed to approach the officials to query their decisions. Only TMs are allowed to approach the officials to seek clarifications.
- 17.3 Schools must ensure that their coaches adhere to the SPSSC Rules and Regulations and Code of Conduct (**Ref Annex A and Annex I**).

18 SUPPORTERS

- 18.1 Schools sending supporters to any competition shall ensure that their students are in proper school attire and that there are sufficient teachers present who would be responsible for the management of and well-being of their students.
- 18.2 Hosting schools reserve the rights to prevent any supporters from entering the competition if he/she failed to comply with the school's Venue Sourcing SOPs.
- 18.3 All supporters are required to remain within the stipulated area for supporters throughout the competition. They are not allowed to be in the competition arena or participate in any form of sideline coaching and/or interference during the game.
- 18.4 Participating schools must ensure that their supporters attending the competition(s) conduct themselves properly (Refer to **Annex A**). In the event that unsportsmanlike behaviour is observed, the Convenor/ hosting school's representative may, at his/her discretion, issue an eviction of the supporter(s) from the training / competition venue.

19 BREACH OF CODE OF CONDUCT BY TMs / PARTICIPANTS / OFFICIALS / COACHES

- 19.1 A Disciplinary Panel comprising members of the NSGOC will be formed to investigate the breach, presided by a Principal, who is the Chairman of the Discipline and Recognition Sub-Committee. The Panel may co-opt members outside the

NSGOC, including personnel from the national sports association, to provide technical advice.

19.2 Any athlete, coach, official, or spectator found guilty of aggressive behaviour through a fight / assault at the NSG, shall be expelled from the NSG, and be banned from it, for the calendar year of the NSG. This shall also apply to all fights / assaults traced to an NSG competition, either immediately, before, during or after the competition.

19.3 An appeal against the decision of the Disciplinary Panel may be submitted by the school (for participants, coaches, and TMs) and/or the official, to the Council, whose decision shall be final (Please refer to Para 13 with regards to the Appeal process).

20 DISQUALIFICATIONS

20.1 A school will be disqualified if:

- a) it fields an ineligible participant who is:
 - i. overaged
 - ii. underaged
 - iii. unregistered (**e.g. For Junior Division: if player registered under sub-team A plays for team B on a given match day**)
 - iv. suspended (with reference to para 14)
 - v. without a valid student pass
 - vi. a non-bona fide student of the school
- b) its participant(s) are not accompanied by a TM
- c) its participant(s) caused the game/match to be abandoned

20.2 All results involving the team which has been disqualified will be considered null and void.

21 ATTIRE

21.1 All participants must be suitably attired in accordance with the requirement of the sport. The attire should bear the school colours/logo/badge or name.

21.2 All jerseys must be clearly numbered on the back in accordance to the submitted NIS registration jersey number. No modification to jerseys is allowed.

21.3 All outfield participants must wear uniform jerseys and the jerseys must not be of any grey tone. The jerseys may carry any number between 1 and 99 inclusive, but 1 is not allowed for field players.

21.4 In the event of a clash in the colour of the team's jerseys or the referees consider that the teams cannot be distinguished by their jerseys, the away team (second named) is obliged to wear another set of contrasting coloured jersey or bibs with numbers.

21.5 All participants shall wear proper shoes with socks.

21.6 No accessories (watches, bangles, jewellery, plastic hairbands etc.) are allowed to be worn by participants. Exceptions shall be allowed only by the NSGOC upon written request and is subjected to approval.

22 OTHER RULES & REGULATIONS

22.1 Playing Time

The game shall consist of three (3) periods of seven (7) minutes with a two (2) minute break between each period. The referee has the right to stop time if the game is delayed due to technical reasons and serious injury.

22.2 Playing Area

The size of the Floorball rink is **(12-16m) by (8-10m)**. It is generally using the half the entire length and width of the indoor sports hall.

22.3 Number of participants

Each team has 2 sub teams. The game shall be contested by three (3) outfield participants. A minimum number of four (4) participants for each sub teams are required for the match to start.

If the number of participants falls below this required minimum (during the start and throughout the game), the sub team concerned shall be taken to have conceded the match with a 0 – 5 score line.

22.4 Team Bench Area

Only the registered participants, TMs, registered officials and coaches (a maximum of five) are allowed within the team bench area (only the names reflected on the team respective day registration form). No unregistered participants, coaches, parents, ex-students or supporters are allowed.

22.5 Timeouts

No timeout for junior division.

22.6 Bench Penalties

Participants will be given a minimum of one (1) minute or maximum of three (3) minutes bench penalty if a serious offence is deemed committed, as stipulated in the IFF rules. Serious breach of discipline such as roughing and causing intentional hurt; a normal match or personal penalty will be melted out according to the discretion of the referee. Participants serving the match penalties will have to sit-out at a neutral bench (bench penalties). There can be a maximum of two (2) participants per team serving the bench penalties.

22.7 Substitution

Participants may be substituted at any time and an unlimited number of times during a match. All substitutions shall take place in the team's own substitution zone which is about three (3) boards' length. **All reserves at the start of the match must start in the 2nd or 3rd period.**

22.8 Team Captain Armlet

The team captain shall wear an armlet on the arm.

22.9 Floorball Stick

In accordance to the official IFF rules, it is compulsory that all outfield participants use sticks that are approved by the IFF and marked accordingly. The blade of stick must not be sharp or broken and its hook must not exceed 3 cm.

22.10 Safety Goggles (optional)

As safety precaution, all outfield participants are encouraged to wear safety goggles to give protection to their eyes.

23 Matters Not Provided For

23.1 All matters not provided for in these Rules and Regulations shall be dealt with by the SPSSC Floorball NSGOC.

24 Amendments

The Singapore Primary Schools Sports Council shall have the right to delete, add or amend the rules and regulations laid down herein.

List of Annexes

Annex	Description
A	SPSSC Mission, Motto & Aspirations
B	Terms of Reference for NSGOC
C	Age group for 2022
D	Management of Appeal for Late/Erroneous Registration
E	Junior Division Competition Format
F	Results Scoring Sample
G	SPSSC Procedure for Appeals Workflow
H	Role of Team Manager
I	Code of Conduct for Coaches
J	NSG Junior Division Floorball Games Rules Overview
K	Layout/ Dimension (Junior)
L	Match Sheet (Junior)
M	Team Line-Up Form (Junior)

Annex A

**SINGAPORE PRIMARY SCHOOLS SPORTS COUNCIL (SPSSC)
AND SINGAPORE SCHOOLS SPORTS COUNCIL (SSSC)**

Mission, Motto and Aspirations

Mission Statement

“To provide quality competition experience to our school athletes to support character development through the pursuit of sporting excellence”

Motto

“Character in Sporting Excellence”

Aspiration 1: *Every athlete an honourable sportsman*

Guiding Principle:

The athlete abides by the rules of the game, gives his best in training and competitions, wins humbly and loses graciously. He participates actively and is committed to the skills development in his sport. He respects his opponents, teammates, coaches, teachers and officials, and displays exemplary conduct both on and off court.

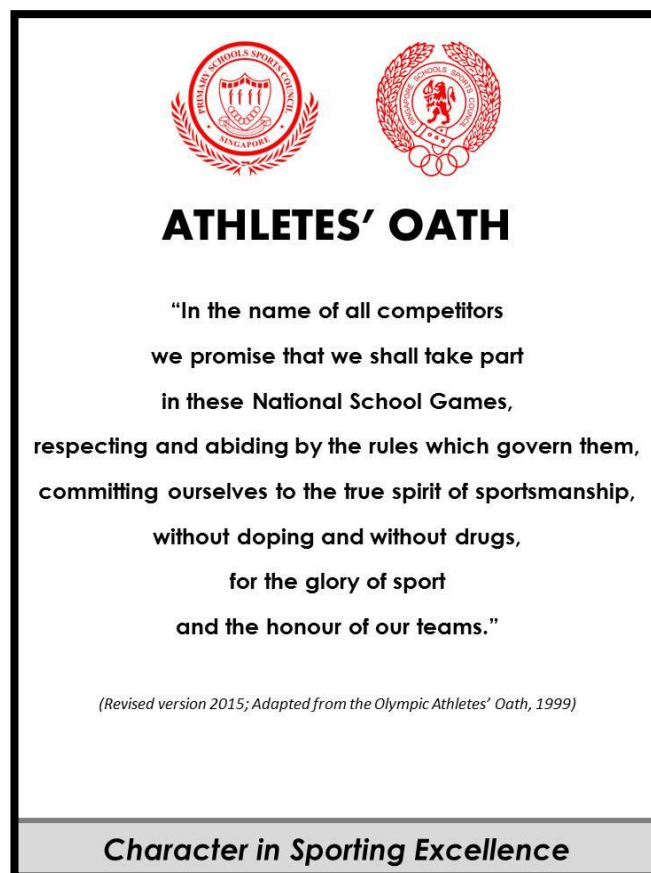

Aspiration 2: *Every teacher and coach an inspiring role model and mentor*

Guiding Principle:

The teacher/coach endeavours to develop each athlete to his fullest potential. He focuses on student-centric and values-driven coaching. He maintains a professional relationship with the athletes and ensures their safety and well-being at all times. As a positive role model, he inspires and motivates the athletes towards greater heights.



COACHES' OATH

*In the name of all the coaches,
we promise to respect all athletes,
officials and coaches in these
National School Games.
We shall act in the best interest of the
athletes and schools,
without doping and without drugs.
We commit ourselves to ensure that the
spirit of sportsmanship and fair play is
fully adhered to and upheld always."*

(Revised 2016; Adapted from the Olympic Coaches' Oath, 2012)

Character in Sporting Excellence

Aspiration 3: *Every official a fair, respectable and competent authority*

Guiding Principle:

The official is well-versed in the rules of the sport, and enforces the laws of the game with impartiality. He is alert and acts decisively when required. He ensures safety for all athletes and explains the rules when required. He upholds the professionalism of the sport.

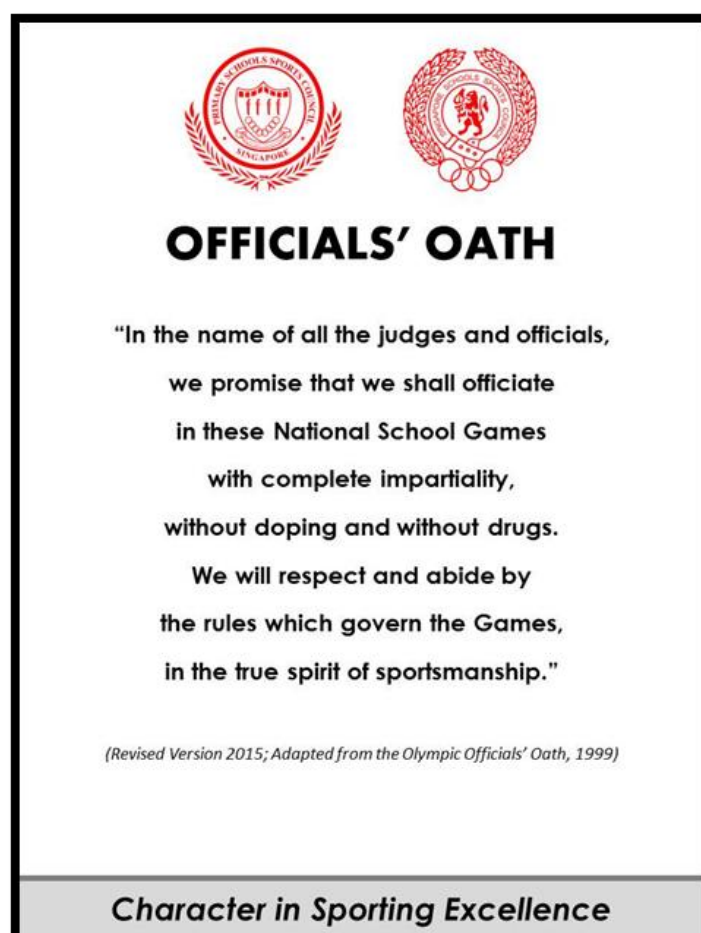

Aspiration 4: *Every parent a supportive partner*

Guiding Principle:

The parent takes interest in his child's training and competitions. He ensures proper nutrition and rest, and actively enquires on his child's progress and development. He works with the teacher and coach, attends games and respects the referee's decisions.

Aspiration 5: *Every spectator a respectful, responsible and caring motivator*

Guiding Principle:

The spectator makes the effort to applaud excellence and fair play. The spectator shows appreciation for the efforts of all athletes, teachers, coaches, officials and organisers. He should cheer to encourage and motivate as well as care for the athletes' well-being. The parent takes interest in his child's training and competitions. He is responsible and keeps the venue safe and comfortable for all.



Aspiration 6: *Every game a safe and enriching learning experience*

Guiding Principle:

The format of competition is developmental and age-appropriate. The games provide athletes with the opportunity to display their sporting prowess, and be recognised for their achievements. Athletes enjoy the competitions, which are conducted under safe and conducive environments.

Annex B

**TERMS OF REFERENCE FOR SPSSC/SSSC
NATIONAL SCHOOL GAMES ORGANISING COMMITTEES (NSGOCs)**

The NSGOCs shall have sub-committees to ensure the successful organising and completion of their respective sports that includes but is not limited to the following functions:

1. TECHNICAL

- a. Establish competition rules and regulations for the sport to ensure age appropriateness and opportunities for skills development, including, but not restricted to:
 - Age grouping / division
 - Format of competition
 - Permitted equipment
 - Field of play
 - Duration of play; intervals
 - Number of participants
 - Substitution rules, etc.
- b. Identify and appoint the technical director and officials for each competition.
- c. Monitor and review baseline safety standards for the competition.
- d. Review and update competition rules and regulations annually and submit Games Recommendations to National School Games Organising Committee or Council Standing Committee for approval, where appropriate.

2. COMPETITION

Organise the competition according to the rules and regulations, and established safety standards, including:

- a. Planning and Execution:
 - i. Work out the competition schedules, fixtures and venues required.
 - ii. Communicate with participating teams on all competition matters, including, but not limited to rules, dates, fixtures, venue, etc.
 - iii. Identify and appoint Competition Director (if applicable) for deployment of officials.
 - iv. Manage competition officials, venues, equipment, medical cover and logistics for effective and efficient conduct of the competition.
- b. Risk Assessment and Management:
 - i. Carry out risk assessment and management planning for each venue, including adherence to the baseline safety standards.
 - ii. Communicate relevant parts of the risk assessment and management plan to all relevant parties.
 - iii. Monitor and manage safety and security issues at the competition venue.

- c. Venue Management:
 - i. Ensure competition venues (including hosting schools) have the following in good condition to support the competition:
 - o Equipment
 - o Line Drawings (if applicable)
 - o Consumables
 - ii. Inform Hosting Schools of competition schedule.
 - iii. Disseminate competition fixtures to all Hosting and Participating Schools once fixtures are confirmed.
 - iv. Inform Hosting and Participating Schools at least three (3) working days before should there be any changes in venue or fixtures.
 - v. Ensure that technical officials and medical support (if applicable) arrive at stipulated time at the competition venue.
 - vi. Remind Team Managers at school briefing:
 - o To check the latest Info Pack of the Hosting Schools in NIS before each match day
 - o To inform their fellow colleagues who may be accompanying their students for the competitions on their behalf
 - vii. Prepare the competition venue, such as display of PDPA notifications, proper allocation of spaces for assembly, warm-up, match, rest areas, spectators, where appropriate.
- d. Results Processing:
 - i. Ensure competition results are promptly and accurately sent to the NSGO for uploading to the NSG website.
- e. Protest Management:
 - i. Respond to query(ies)/protest(s) by participating school(s) during the competition.
 - ii. Conduct investigations and resolve the query(ies)/protest(s) relating to the competition.

3. RECOGNITION, APPEAL AND DISCIPLINE

- a. Recognition
 - i. Develop and implement appropriate recognition (including recognition criteria), to support the desired outcomes of the National School Games, such as Sportsmanship Award.
 - ii. Collect and communicate good stories to relevant party(ies), including participating schools, MOE HQ and the media where appropriate.
 - iii. Plan and organise prize-giving ceremonies for the competition.
- b. Appeal
 - i. Work with Competition and Technical Sub-Committees to conduct investigations with all parties involved, in consultation with the Games Advisor and Vice-Chairman of the Standing Committee where relevant.
 - ii. Resolve all appeals and respond to relevant party(ies) on the outcome within a week of incident reported.
 - iii. Update SPSSC/SSSC Standing Committee on the outcome of the queries / protests / appeals, where warranted.

- c. Discipline
 - i. Work with Competition and Technical Sub-Committees to conduct investigations pertaining to disciplinary case(es) with all parties involved, in consultation with the Games Advisor.
 - ii. Resolve all disciplinary case(es) and respond to relevant party(ies) on the outcome within a week of the case(es).
 - iii. Develop disciplinary policies and systemise processes to manage student(s), teacher(s), coach(es) and umpire(s) for alignment to the Councils' mission, motto and aspirations.

Age Group for 2022

S/N	Sports/Games	Senior Division	Junior Division	Age Dispensation	Remark
1	Floorball	1 Jan 2011 1 Jan 2010 --- 31 Dec 2010 2 Jan 2009 --- 31 Dec 2009	1 Jan 2014 1 Jan 2013 --- 31 Dec 2013 1 Jan 2012 --- 31 Dec 2012 2 Jan 2011 --- 31 Dec 2011 1 Jan 2011 (<i>subject to conditions laid out in para 2.1</i>)	Not applicable	

Summary on Registration of Number of Entries for Floorball in 2022

Sport	Junior Division
Floorball	Max no. to register: 18 participants (2 sub-teams of 9 players) Min. no. to register: 8 participants (2 sub-teams of 4 players)

Management of Appeal for Late/Erroneous Registration Workflow

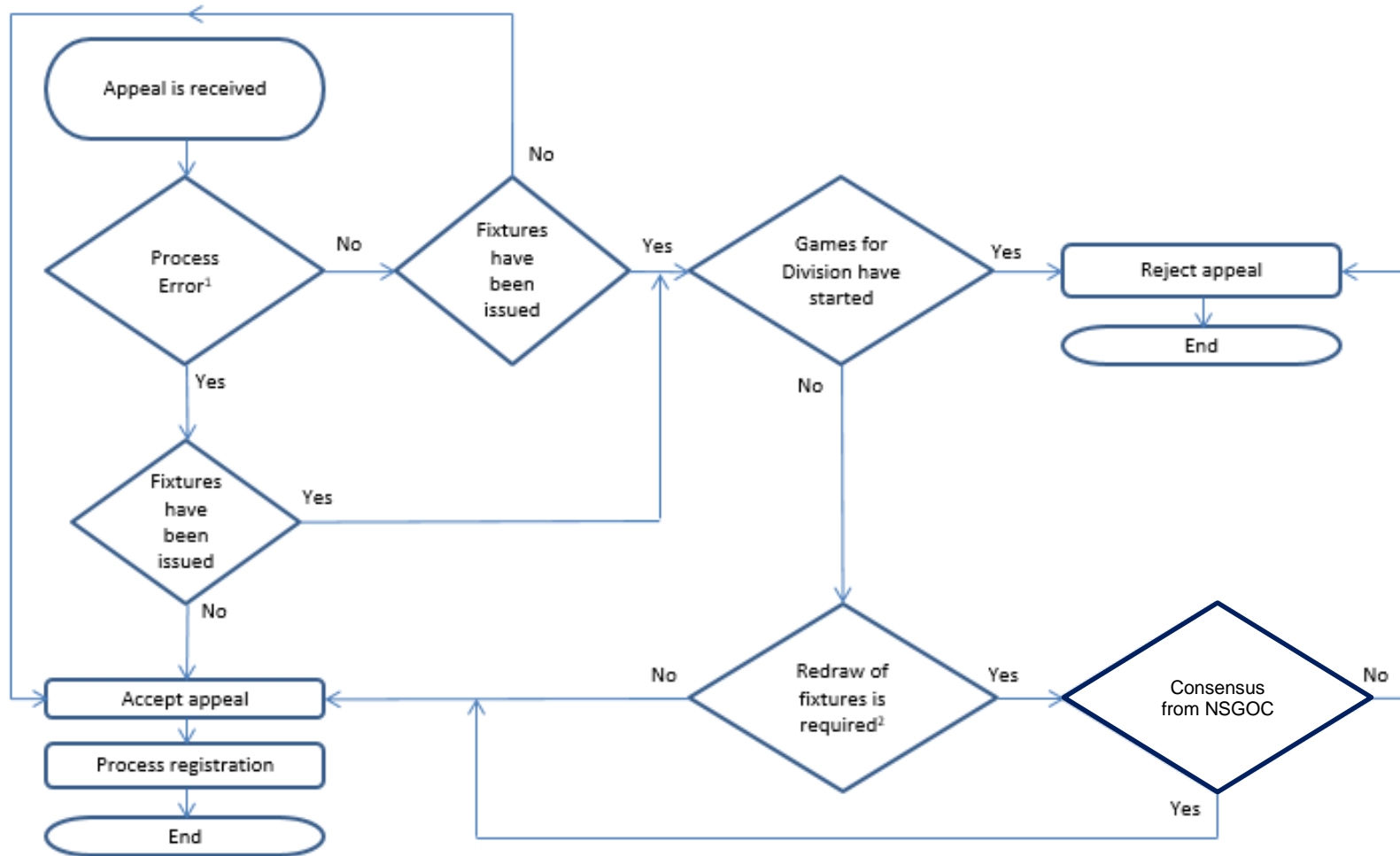

Note:

¹: Refers to errors such as technical glitches, miscommunication by Organiser, erroneous information by Organiser, etc.

²: Required if (i) appellant is a seeded team, (ii) there is change in format/number of groups

Junior Division Competition Format

Number of Teams		Group			No of tiers	From each group, which team plays where			
3 to 7 teams		One-Group			1 tier				
Number of Teams	Group A		Group B			Tier 1	Tier 2	Tier 3	
8 teams	4		4		2 tiers	Top 2	The rest		
9 teams	4		5			Top 2	The rest		
	5		4						
10 teams	5		5						
11 teams	5		6			Top 2	The rest		
	6		5						
12 teams	6		6						
13 teams	6		7			Top 2	The rest		
	7		6						
14 teams	7		7						
Number of Teams	Group A	Group B	Group C						
12 teams	4	4	4			Top 2	The rest		
13 teams	4	4	5		2 tiers	Top 2	The rest		
	5	4	4						
14 teams	4	5	4						
	5	4	5						
15 teams	5	5	4						
	5	5	5			Top 2	The rest		
Number of Teams	Group A	Group B	Group C	Group D					
16 teams	4	4	4	4		2 tiers	Top 2	The rest	
17 teams	5	4	4	4	Top 2				
	4	5	4	4					
	4	4	5	4					
	4	4	4	5					
18 teams	5	5	4	4	Top 2				
	5	4	4	5					
	4	5	5	4					
	4	4	5	5					
19 teams	5	5	5	4	Top 2				
	5	5	4	5					
	5	4	5	5					
	4	5	5	5					
20 teams	5	5	5	5	Top 2				
21 teams	6	5	5	5	Top 2				
	5	6	5	5					

	5	5	6	5								
	5	5	5	6								
22 teams	6	6	5	5		Top 2						
	6	5	5	6								
	5	6	6	5								
	5	5	6	6								
23 teams	6	6	6	5		Top 2						
	6	6	5	6								
	6	5	6	6								
	5	6	6	6								
24 teams	6	6	6	6	3 tiers	1st and 2nd	3rd and 4th	The rest				
25 teams Girls	7	6	6	6								
	6	7	6	6								
	6	6	7	6								
	6	6	6	7								
26 teams	7	7	6	6								
	6	7	7	6								
	7	6	6	7								
	6	6	7	7								
27 teams	7	7	7	6								
	7	7	6	7								
	7	6	7	7								
	6	7	7	7								
28 teams	7	7	7	7								
43 teams Boys	5	5	5	5	5	6	6	6	3 tiers	1st and 2nd	3rd and 4th	5th and 6th

Current 2018 Junior Division Numbers and Grouping
Classification Round

Girls 25 teams

3 groups of 6 and 1 group of 7

Boys 43 teams

5 groups of 5 and 3 groups of 6

Tier 1

Girls 8 teams

2 groups of 4 - round robin (12 matches)

1st v 2nd (2 matches)

3rd v 4th (2 matches)

Playoff for 1st-8th (4 matches)

4 medallists

Boys 16 teams

4 groups of 4 – round robin (24 matches)

1st v 2nd (4 matches)

3rd v 4th (4 matches)

Playoff for 1st to 16 (8 matches)

8 medallists

Tier 2

Girls 8 teams

2 groups of 4 - round robin (12 matches)

1st v 2nd (2 matches)

3rd v 4th (2 matches)

Playoff for 1st -8th (4 matches)

4 medallists

Boys 16 teams

4 groups of 4 – round robin (24 matches)

1st v 2nd (4 matches)

3rd v 4th (4 matches)

Playoff for 1st to 16 (8 matches)

8 medallists

Tier 3

Girls 9 teams

3 groups of 3 – round robin (9 matches)

1st v 1st (3 matches) 1-3rd

2nd v 2nd (3 matches) 4-6th

3rd v 3rd (3 matches) 7-9th

4 medallists

Boys 11 teams

2 groups of 4 and 1 of 3 (9 matches)

1st place teams in 1 group (3 matches) 1-3rd

2nd place teams in 1 group (3 matches) 4-6th

3rd place teams in 1 group (3 matches) 7-9th

4th place v 4th place (1 match) 10-11th

Sample of groupings based on participation of 41 schools

(Actual number of groups in the Classification Round and Tier Round depends on the total number of registered teams)

Classification Round			
<u>Group A</u>	<u>Group B</u>	<u>Group C</u>	<u>Group D</u>
A1	B1	C1	D1
A2	B2	C2	D2
A3	B3	C3	D3
A4	B4	C4	D4
A5	B5	C5	D5
<u>Group E</u>	<u>Group F</u>	<u>Group G</u>	<u>Group H</u>
E1	F1	G1	H1
E2	F2	G2	H2
E3	F3	G3	H3
E4	F4	G4	H4
E5	F5	G5	H5
			H6

An online draw will be conducted for Classification and Tier Rounds.

Top 2 schools from each group in the Classification Round will be awarded achievement pins

Tier Round			
Tier 1			
<u>Tier 1a</u>	<u>Tier 1b</u>	<u>Tier 1c</u>	<u>Tier 1d</u>
1 st Group A	1 st Group B	1 st Group C	1 st Group D
1 st Group E	1 st Group F	1 st Group G	1 st Group H
2 nd Group H	2 nd Group G	2 nd Group F	2 nd Group E
2 nd Group D	2 nd Group C	2 nd Group B	2 nd Group A
Tier 2			
<u>Tier 2a</u>	<u>Tier 2b</u>	<u>Tier 2c</u>	<u>Tier 2d</u>
3 rd Group A	3 rd Group B	3 rd Group C	3 rd Group D
3 rd Group E	3 rd Group F	3 rd Group G	3 rd Group H
4 th Group H	4 th Group G	4 th Group F	4 th Group E
4 th Group D	4 th Group C	4 th Group B	4 th Group A
Tier 3			
<u>Tier 3a</u>		<u>Tier 3b</u>	
5 th Group A		5 th Group B	
5 th Group C		5 th Group D	
5 th Group E		5 th Group F	
5 th Group G		5 th Group H	
6 th Group H			

Prize Structure (for each tier)

Tier 1			
<u>Tier 1a</u>	<u>Tier 1b</u>	<u>Tier 1c</u>	<u>Tier 1d</u>
1 st	1 st	1 st	1 st
2 nd	2 nd	2 nd	2 nd
3 rd	3 rd	3 rd	3 rd
4 th	4 th	4 th	4 th
Tier 2			
<u>Tier 2a</u>	<u>Tier 2b</u>	<u>Tier 2c</u>	<u>Tier 2d</u>
1 st	1 st	1 st	1 st
2 nd	2 nd	2 nd	2 nd
3 rd	3 rd	3 rd	3 rd
4 th	4 th	4 th	4 th
Tier 3			
<u>Tier 3a</u>		<u>Tier 3b</u>	
1 st		1 st	
2 nd		2 nd	
3 rd		3 rd	
4 th		4 th	
5 th			

Prizes (medals/ trophies) will be awarded to top school of each tier (based on para 7.1: up to the top 40% of participants / teams of each tier can be awarded with medals)

Results Scoring Sample

SCH	A		Pts	B		Pts	C		Pts	D		Pts	Total
A				5-1	2-0	6	4-1	2-0	6	1-1	1-1	2	14
B	1-5	0-2	0				1-1	0-3	1	1-0	3-4	3	4
C	1-4	0-2	0	1-1	3-0	4				2-0	1-4	3	7
D	1-1	1-1	2	0-1	4-3	3	0-2	4-1	3				8

Results from 2 sub-team scores will give the total points

Types of Points Outcomes for one school

Sub-Team 1	Sub-Team 2	Total Pts	Overall School Outcome
Win (3)	Win (3)	6	Win
Win (3)	Draw (1)	4	Win
Win (3)	Lose (0)	3	Draw
Draw (1)	Draw (1)	2	Draw
Draw (1)	Lose (0)	1	Lose
Lose (0)	Lose (0)	0	Lose

Sample of a 2 school tie

Sch	A		Pts	B		Pts	C		Pts	D		Pts	Total	GF	GA	GD	Position
A				4-2	2-1	6	8-0	4-0	6	1-1	3-3	2	14	22	7	15	1
B	2-4	1-2	0				1-4	2-1	3	0-7	0-4	0	3	6	19	-13	4
C	0-8	0-4	0	4-1	1-2	3				2-4	1-2	0	3	8	21	-13	3
D	1-1	3-3	2	7-0	4-0	6	4-2	2-1	6				14	21	7	14	2

GD
GF

Sample of a 3 school tie

If it is a 3 school tie, the 4th school is removed from the calculations

SCH	A		Pts	B		Pts	C		Pts	D		Pts	Total	GF	GA	GD	Position
A				2-4	1-2	0	1-2	1-2	0	0-1	1-2	0	0	6	13	-7	4
B	4-2	2-1	6				3-0	3-0	6	0-1	0-1	0	12	12	5	7	1
C	2-1	2-1	6	0-3	0-3	0				1-0	1-0	6	12	6	8	-2	3
D	1-0	2-1	6	1-0	1-0	6	0-1	0-1	0				12	5	3	2	2
Tied Schools results only																	
B							3-0	3-0	6	0-1	0-1	0	6	6	2	4	1
C				0-3	0-3	0				1-0	1-0	6	6	2	6	-4	3
D				1-0	1-0	6	0-1	0-1	0				6	2	2	0	2

GD - 1st
GD - 3rd
GD - 2nd

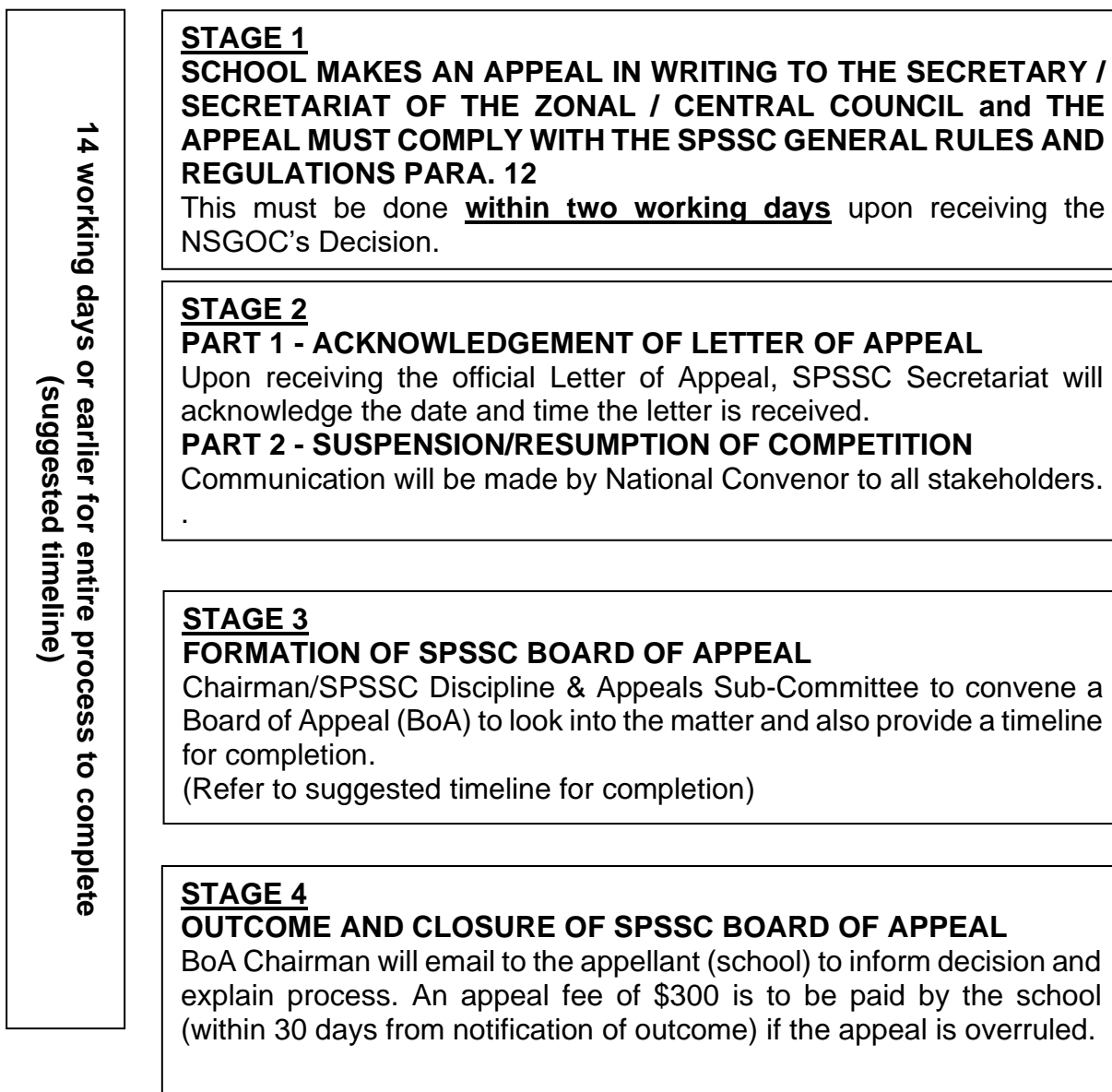
SPSSC WORKFLOW FOR APPEALS

As in accordance with the SPSSC General Rules and Regulations under rule 13.4, the decision of the Board of Appeal or the Standing Committee shall be final.

SINGAPORE PRIMARY SCHOOLS SPORTS COUNCIL

Role of the Team Manager

The team manager (TM) will represent the school on all matters pertaining to the duty of care, student management and competition matters relating to the participants from his / her school. He/she must be a good role model for the participants and are expected to conduct themselves well in carrying out their duties. He/she will do the following:

	Terms of Reference
1	Point of contact between the National School Games Organising Committee (NSGOC) and the Principal (school).
2	Attend all briefings and/or meetings called for by the respective NSGOCs.
3	Check & verify the fixtures and schedules involving the school.
4	Ensure the accuracy of participants' particulars in the registration and that students are not placed in the wrong division.
5	Make transport arrangements for the participant(s).
6	To chaperone participant(s) to and from the competition venue and remain with the participant(s) throughout the duration of play.
7	Cooperate with NSGOC & officials and abide by the rules and regulations of the competition.
8	Submit team list & other necessary documents when required to.
9	Manage the coach, participant(s) and supporter(s), if any, to ensure that they adhere to the Code of Conduct as provided in SPSSC Rules & Regulations.
10	Arrange for a replacement, in the event that he/she is not able to perform his/her duty, including when it is halfway through the competition
11	Duty of care for the participant(s) safety and well-being and to ensure that the participant(s) is/are medically covered e.g. first aid kit.
12	Contact the school immediately in the event of an injury or emergency.
13	Do not speak to the media unless with permission from the school
14	Represent the school in matters pertaining to formal appeals/protests (as required by the sport)
15	Accompany participant(s) at disciplinary board meetings if the occasion arises.
16	Any other matters pertaining to the duty of care, student management and competition matters relating to the participants from his / her school.

Code of Conduct for Coaches

- 1) Coaches must be good role models for the student athletes and are expected to conduct themselves well in carrying out their duties.
- 2) They are to observe the rules and regulations of the National School Games and honour the Coaches' Oath.
- 3) They should not replace the role of the team manager.
- 4) They are to prepare the training schedule for the team, in consultation with the Principal and the teacher in-charge (i.e. 30-week programme)
- 5) They are not allowed into the competition area except where the rule of the sport requires the presence of the coach e.g. Softball and Gymnastics.
- 6) They cannot represent the school in any matters.
- 7) They must not interfere with the organisation of the competition.
- 8) They are not allowed to approach the officials to query their decisions. Only team managers are allowed to approach officials to seek clarifications.
- 9) Coaches violating the rules will be asked to leave the competition arena.
- 10) Action will be taken against the school if the coaches fail to comply with the competition rules.
- 11) It is the responsibility of coaches to adhere to the rules and to be well versed with the competition rules.
- 12) They must ensure that the student athletes have adequate rest and are given water breaks.
- 13) Coaches should refrain from using foul language or speak in a tone not becoming of proper behaviour.

NSG Junior Division Floorball Games Rules Overview

1. **Age Group:** 9- to 11-year-olds (no age dispensation)
2. **Schools Competition Period:** Term 3 Week 2 to Term 3 Week 10
3. **Facilities & Equipment:**
 - **Playing Area:** 12-16m by 8-10 m
 - **Goalposts:** Small goalposts (90cm by 60cm) x 2pcs at each end [Total 4 goalposts in the playing area]
 - **No-Go-Zone:** In front of the goalposts (90cm by 60cm) [Perimeter of the face of the goalpost]
4. **Team Registration (Players Registration)**
 - Maximum number of registered players: 18 (2 sub-teams of 9 players each)
 - Minimum number of registered players: 8 (2 sub-teams of 4 players each)
 - Minimum number present to compete (start the match): 4 players per sub-team
 - Players on court: 3 outfield players (with no goalkeeper)
5. **Playing Format**
 - **Playing Time:** 3 periods of 7 minutes
 - **Rest Interval Between Periods:** 2 minutes
6. **Substitution during matches:**
 - **Rolling Substitution**
 - Any number of substitutions during the match.
 - All players **must play** and be given an opportunity to **start a period**.
 - Starting line-ups for the 3 periods must include all players.
7. **Competition Format:** Classification round with teams progressing to various tiers based on the placing in the classification group matches.
8. **Games Rules**
 - The Junior Division Floorball Competition shall be conducted in accordance with the existing laws/rules of the game as approved by the International Floorball Federation (IFF); and as governed by the Rules and Regulations of the Singapore Primary Schools Sports Council (SPSSC).
 - The competition will be played three-a-side (or 3-on-3), with no goalkeeper and using two small goalposts at each end of the court.
 - No player is allowed to step into the 'No-Go-Zone'. If a defending player (or any body parts) **actively** enters the zone to stop the ball from entering into the goal or to clear the ball from the zone, a penalty shot for the opposing side will be awarded. The penalty shot will be taken from the face-off cross (can shoot any of the 2 unguarded goalposts).
 - Players can be substituted in and out of the game at any time (rolling substitution). However, all players must play and must be given the chance to start each period
 - The stick cannot be raised above the hips during the forward and backward action of the swing subject to danger.
 - A player is not allowed to receive or play the ball above the knee level with the stick in a dangerous manner.
 - A player is not allowed to jump to receive or play the ball.

- A free hit will be given to the opposing team if a foul (direct free hit) is committed or if the ball goes out of play (direct hit).
- A 1-minute bench penalty will be awarded against a player for the following offence:
 - Hitting, blocking, lifting or kicking and opponent's stick with no possibility to reach the ball.
 - Holding an opponent, or an opponent's equipment.
 - Tackling or tripping an opponent when trying to reach the ball.
 - When a field player stops the ball with his hand, arm or his head.
 - When a field player stops or plays the ball lying or sitting down.
 - When a field player participates in play without a stick.
 - When a player protest against the referee's decisions in a disturbing or otherwise incorrect way.
- A hit-it will be taken when the ball goes out of play (went out of the playing area)
 - Hit-in taken on the cross (equidistant of the end goalposts) if the ball goes out of play behind the goalposts (width of the playing area)
 - Hit-in taken near to the where the ball goes out of play along the length of the playing area
- All opposing players are to move 3 meters from the ball during a re-start of play after an offence has been penalized and also during any hit-in.

9. Technical Requirement (Logistics) for 2 courts (playing areas)

- 52 straight boards (no rounded corner boards will be used) x 2 courts
- 8 small-goal posts
- 4 team benches required
- 1 match sec tables
- 1 portable timer
- 1 venue manager
- 2 referees (to update scores to venue manager)
- Tapes to mark out zones, face-off and corners

LAYOUT/ DIMENSION (JUNIOR DIVISION)

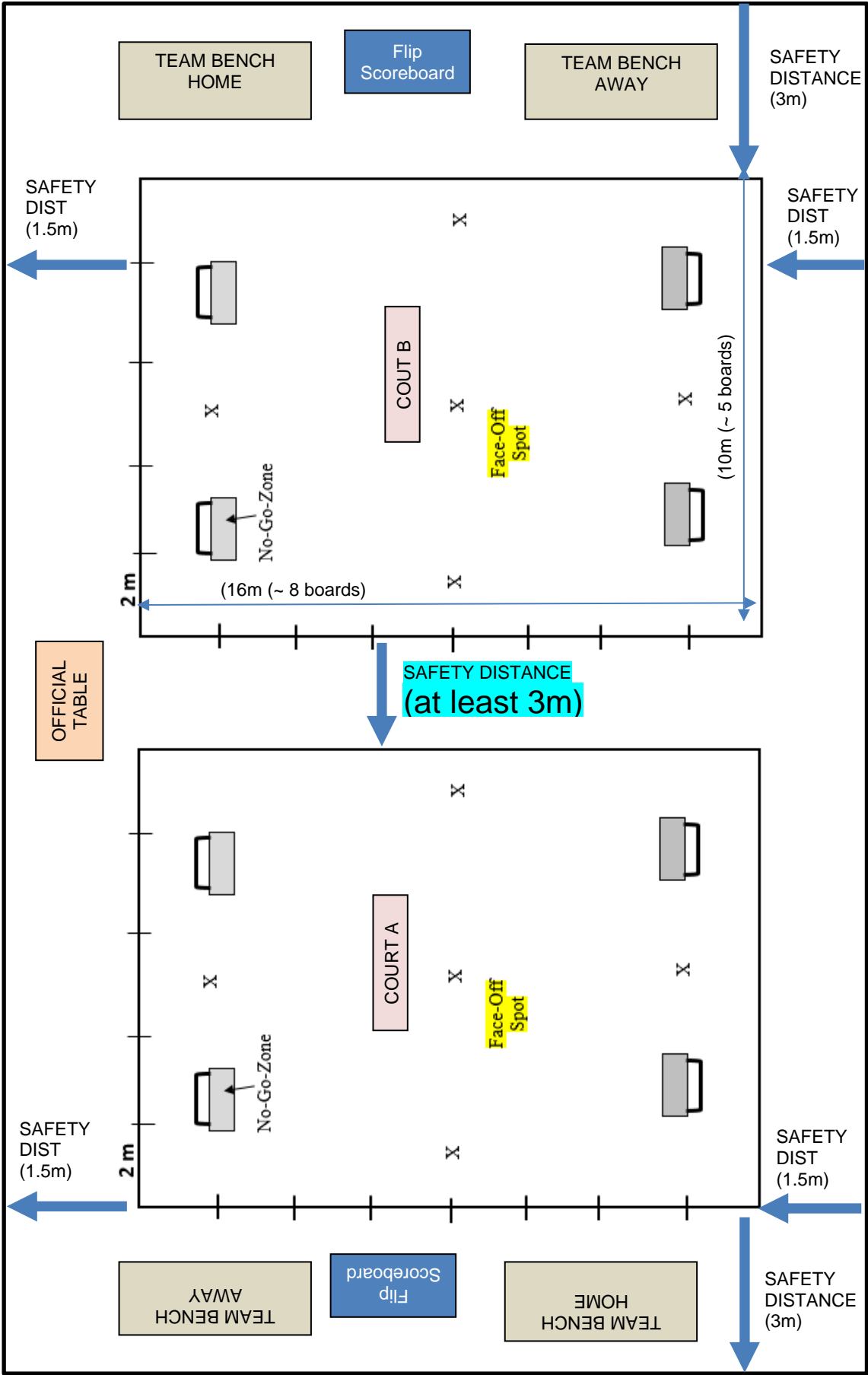

Breadth= 19m



SPSSC National School Games Competition 2022

MATCH SHEET- To be submitted to Venue Manager prior to the start of each match.

SECTION A: GAME DETAILS

Name of Competition:	SPSSC NATIONAL FLOORBALL COMPETITION JUNIOR DIVISION		
Date:	Time:	Venue:	
Home Team (H):		Away Team (A):	

SECTION B: SCORE TABLE

Sub-Team	PERIOD 1 SCORE		PERIOD 2 SCORE		PERIOD 3 SCORE		FINAL SCORE	
	(H)	(A)	(H)	(A)	(H)	(A)	(H)	(A)
A	(H)	(A)	(H)	(A)	(H)	(A)	(H)	(A)
B	(H)	(A)	(H)	(A)	(H)	(A)	(H)	(A)

SECTION C: ACKNOWLEDGEMENT

ACKNOWLEDGEMENT BY REFEREES:	I verify that the final score between the Home Team: (name of school) Away Team: (name of school) For the game held on (date & time) is <u>correct</u>	
	Name & Signature of Referee 1:	
	Name & Signature of Referee 2:	
ACKNOWLEDGEMENT BY TEACHERS-IN-CHARGE	HOME TEAM	Name & Signature of Teacher:
	AWAY TEAM	Name & Signature of Teacher:
ACKNOWLEDGEMENT BY VENUE MANAGER	I hereby state that I have fulfilled and completed my duty diligently. I would like to report the following: please tick one from (1) or (2): (1) <input type="checkbox"/> The match has proceeded without any serious incident. (2) <input type="checkbox"/> I would like to report an incident related to the following (please indicate) <input type="checkbox"/> Accident / serious injury – ambulance was called <input type="checkbox"/> Assault / unsportsmanlike play <input type="checkbox"/> Audience disruption <input type="checkbox"/> Other(s):	
	For any incident that has occurred in (2), I will inform the following immediately: <ul style="list-style-type: none"> ▪ Organising Secretary of the Tournament ▪ PSQEB Games Advisor Name & Signature Venue Manager:	



SPSSC National School Games Competition 2022
(Junior Division)
TEAM LINE-UP FORM

Team Manager to complete team line-up form and submit it together with team registration form to Venue Manager before the start of the game.

Name of Tournament:	SPSSC NATIONAL FLOORBALL COMPETITION JUNIOR DIVISION		
Date:	Time:	Venue:	
Name of School:		Name of competitor (school):	

Sub Team A	Indicate player's jersey number		
Period / Player	Player 1	Player 2	Player 3
Period 1			
Period 2			
Period 3			

Sub Team B	Indicate player's jersey number		
Period / Player	Player 1	Player 2	Player 3
Period 1			
Period 2			
Period 3			

I confirmed that the above information is correct.

Name of Team Manager: _____

Signature: _____