



National Schools Games National Netball Competition 2022 Competition Rules and Regulations (*Updated on 4 May 2022*) Junior Division

This document outlines the rules and regulations for the conduct of and participation in the National School Games (NSG). These rules and regulations should be interpreted and implemented in alignment to the spirit of the SPSSC's Mission, Aspirations and Motto (Ref Annex A).

SECTION A – ADMINISTRATIVE RULES & REGULATIONS

1 ORGANISATION STRUCTURE AND GOVERNING BODIES

- 1.1 The National School Games (NSG) shall be conducted:
- 1.1.1 As governed by the General Rules and Regulations of the Singapore Primary Schools Sports Council.
 - 1.1.2 According to the laws/rules established by the International Netball Federation (INF).
 - 1.1.3 Adhering to the Baseline Safety Standards for the NSG.
 - 1.1.4 In the event that the rules and regulations are modified for safety/developmental reasons to suit the level of our school students, it must be clearly stated in the respective sports rules and regulations.
 - 1.1.5 In the absence of a set of recognised rules to govern the occurrence of situations during the competitions, the respective National School Games Organising Committee shall make the final decision.

2 DIVISIONS (age group to follow the year of birth)

- 2.1 For Netball, the following age group divisions apply:

Junior Division
1 Jan 2014
1 Jan 2013 --- 31 Dec 2013
1 Jan 2012 --- 31 Dec 2012
2 Jan 2011 --- 31 Dec 2011
1 Jan 2011 (<i>subject to conditions laid out in para 2.1</i>)

- 2.2 All students shall compete in the respective divisions set out in the General Rules & Regulations (Annex C) **with the exception of those born on 1 January who have**

been given approval for deferment by MOE during P1 registration. These students will compete in the division with the cohort that they are studying with.

2.2.1 With effect from 2021, students who are born on 1 January and have participated in NSG previously shall follow the rules stated in Para 2.1. This rule will supersede all previous decisions.

2.2.2 This exception in Para 2.1 does not apply to students who are born on 1 January and have repeated a year of study.

2.3 All students can only compete in one division of that particular sport within the same year.

3 ENTRIES

3.1 Each school is eligible to enter only one team in the Girls Senior Division.

3.2 All entries must be submitted through the Registration Module at <https://nsg.moe.edu.sg/nis/#!/login> on or before the stipulated closing date. This includes details of participants along with the necessary supporting documents.

- a) Baseline Safety Standards Acknowledgement Form
- b) Supporting documents for Special/Transfer case students
- c) Other forms as determined by the respective NSGOCs

3.3 Appeals for late/ erroneous entries¹ submitted by schools will be accepted on a case-by-case basis with consensus from the Organising Committee. (Please refer to **Annex B**).

3.3.1 Schools must write in through the Principal, to inform the Convenors of any appeal at least one (1) working day before the next match.

4 REGISTRATION OF PARTICIPANTS

4.1 The total number of participants to be registered shall be a minimum of 10 players and a maximum of 20² participants for the Junior Division for the Zonal competitions. For 2022, there will not be National championships for Junior Division.

4.2 If a school chooses not to register the maximum number of players allowed at the time of registration, the school shall not be permitted to register additional players subsequently.

4.3 If the pupil has represented his school in a competition prior to the re-admission, then she shall not be eligible to represent the new school for that particular competition.

4.4 Pupils requesting for a transfer after the re-admission exercise may not represent their new school until the transfer has been officially effected.

4.5 Only in the event that any of the player(s) registered be transferred or has/have to leave school as a result of re-admission, schools shall be allowed to replace the affected player(s).

4.6 However, no replacement of player is allowed once the Championship reaches the semi-final stage.

¹ The rule applies to late/ erroneous in entries and registration of participants.

² The provision for registering up to a maximum of 20 students is only applicable in 2022 to allow schools to manage their students' participation in the competition in view of unexpected COVID cases in the team. These students can be vaccinated or unvaccinated.

- 4.7 International pupils can only be registered to play for their school **after** they have been issued with the pupil passes from the Immigration and Checkpoints Authority.
- 4.8 International pupils who are in the school on exchange programme are not allowed to represent the school.
- 4.9 Pupils granted Leave of Absence (LOA) by MOE will be allowed to represent the school.
- 4.10 Registration constitutes representation, that is, once a pupil is registered to play for a school, he or she is deemed to have represented his or her school. Hence, the pupil is not allowed to represent another school in Netball in the same year.

SECTION B – COMPETITION RULES & REGULATIONS

5 COMPETITION FORMAT

5.1 PRELIMINARY ROUND - LEAGUE

- 5.1.1 For Team Games, there must be a minimum of **three** (3) registered teams from **three** (3) different schools before a team competition can be organized.
- 5.1.2 The competition shall be organised on an inter-school league format. Where entries are grouped, each group shall have a minimum of four (4) teams³.
- 5.1.3 The league winner shall be the team with the greatest number of points after all games in each group have been played.
- 5.1.4 In the event of a tie in league points between 2 teams, the team that has beaten the other team shall be declared the winner.
- 5.1.5 In the event of a tie in league points between two teams, where the game between them has ended in a draw, the league winner shall be determined by goal differences, i.e. goals for minus goals against.
- 5.1.6 In the event of a draw between 2 teams tied in league points and where a walkover is involved, positional play will be determined by goal difference but disregarding all games played by that team which conceded the walkover.
- 5.1.7 In the event of a tie in league points among 3 teams, position placing will be determined by goal difference, computed based on the scores of the games played amongst the 3 teams only.
- 5.1.8 In the event of there being a tie in goal difference, then the team which has scored the greatest number of goals shall be declared the winner. If the tie persists, a replay shall be ordered. In the event of a draw at the end of the replay, the extra time rule shall apply. (Refer to 5.3)

5.2 SEMI-FINALS/ FINALS - KNOCKOUT

The winner and runner-up of each group shall enter into a criss-cross competition.

³ The rule applies when the competition is organised in format involving two and more groups. The rule is **NOT** applicable for Zonal competition when a zone has less than four teams advancing to the national competition due to disqualification and/or other reasons.

The winner of group I will meet the runner-up of group II and vice-versa. The winners of the two groups shall then play a final match to decide the champion and runner-up. The losers will play for the 3rd and 4th positions. This format may be altered based on the prevailing format for the competition.

5.3 EXTRA TIME PLAY

In games where a winner must be determined and in the event of a draw at full-time, there shall be an interval of two (2) minutes. Game will resume from the last centre pass and the game continues for ten (10) minutes, consisting of two (2) halves of five (5) minutes each with an interval of one (1) minute at half-time. Teams shall change ends at half-time and begin Centre pass that is to be taken by the team entitled to the next Centre pass. If there is still a draw after the extra time, a visual signal shall be used to indicate that play shall continue until one team has a two (2) goal advantage.

5.4 Any deviation from the competition format requires approval from the Council or Standing Committee.

6 AWARD OF LEAGUE POINTS

The following scoring system shall apply:

- i) 3 points for a win
- ii) 1 point for a draw
- iii) 0 points for a loss/ walkover

7 PRIZES

Prizes and plaques for 1st, 2nd, 3rd and 4th placings shall be awarded at the Zonal competitions.

8 REPORTING AND GRACE PERIOD

Fifteen minutes (15 minutes) grace is allowed. The NSGOC may at his/her discretion extend this grace period if he/she thinks the extension of grace period is justifiable (e.g. in special cases when delay may be caused by traffic jams, floods, etc). However, the team concerned must contact the Convenor, Organising Secretary or Venue Manager concerned to inform him/her of the delay. Teams must abide by the decision of the Convenor or his/her representative. Should the game not start, the decision on whether the game is a walkover or rescheduled will be communicated to the respective schools after the NSGOC makes a decision.

9 POSTPONEMENT

9.1.1 The Convenor or his/her representative shall, at his/her discretion, decide to postpone a match if it thinks the venue is unfit for play, or for any other valid reasons for which it deems a postponement is in order. Schools must abide by the decision of the Convenor or his/her representative.

9.1.2 In the event the game is postponed due to inclement weather, it will be played at the next available day. For games that had started to play, the game shall commence from the last completed half. The scores from the last completed half shall be carried over.

10 WITHDRAWAL OR WALK-OVER

10.1 Any withdrawal or walk-over by a team is considered contrary to the spirit of the game.

- 10.2 Schools participating in the tournament should not withdraw or give a walk over.
- 10.3 For each withdrawal or walk-over, a written explanation duly endorsed by the Principal shall be submitted to the Convenor and Game Advisor within two (2) working days.

11 ABANDONED GAME

- 11.1 The umpire is required to submit a written report on an abandoned game within one (1) working day to the National Convenor.
- 11.2 For decision on abandoned game, refer to Para 20 on disqualifications.

12 PROTEST

- 12.1 Any clarification on points of laws/rules must be lodged immediately by the Team Manager (TM) to the referee. The decision taken by the umpire will be final.
- 12.2 All protests and disputes shall be referred to the NSGOC Disciplinary Committee, which comprises of the NSGOC members: National Convenor, Chair Disciplinary Committee and Games Advisor. The protest(s) must reach the Committee within one (1) working day following the match to which it relates. The protest must be in writing and duly signed by the Principal. Protest fee of one hundred and fifty-dollars (\$150) will be deducted from the protesting school's account, via IFAAS.
- 12.3 The NSGOC Disciplinary Committee will deliberate on the protest within three (3) working days. The decision will then be made known in writing to the school concerned by the next day.
- 12.4 If the protest is upheld the protest fee will be refunded to the school concerned. If it is overruled, the protest fee of \$150 (plus GST) will be deducted from the protesting school's account, via IFAAS.
- 12.5 When there is conflict of interest, the school involved will not sit in the committee considering the protest.

13 APPEAL

- 13.1 Notices of appeal shall be lodged with the Secretary / Secretariat of the Zonal / Central Council within two (2) working days upon receiving the NSGOC's decision. The appeal must be in writing (or email) and duly signed by the Principal.
- 13.2 An appeal fee of three hundred dollars (\$300) will be deducted from the appealing school's account via IFAAS if the appeal is overruled.
- 13.3 A Board of Appeal will deliberate on the appeal. The decision of the Board of Appeal or the Standing Committee shall be absolute and final. (Please refer to **Annex C**)

14 SUSPENSION

A participant suspended by any one of the following bodies is barred from participating in NSG competition for that sport for the period of suspension:

- the School
- the Zone Council

- the SPSSC
- the Netball Singapore

15 TEAM MANAGERS

- 15.1 Each participating team must be accompanied by a TM who shall remain with the team throughout the duration of play. (Please refer to **Annex D**)
- 15.2 The team manager shall be a teacher appointed by the participating school.
- 15.3 Team managers are not allowed to interfere with the final decision taken by the referees on points of laws/rules after clarification has been sought. If such interference results in disruption of any match, a report shall be made by the NSGOC for appropriate action.
- 15.4 Failure to comply with rule 15.1 to 15.3 shall lead to the disqualification of the team.

16 UMPIRES

- 16.1 The Vendor shall provide umpires, who are qualified umpired from Netball Singapore for all the matches.
- 16.2 The teacher in-charge must be present at the game his/ her school is scheduled to umpire. Three (3) points shall be deducted from the school that fails to provide an umpire at the start of the game.
- 16.3 The venue manager will oversee time-keeping for actual match, bench/match penalty and update score. He/she will complete and submit the match record form to the NSGO Executive at the end of each match day. He/she will update the NSGO Executive with the summary of all scores for updating on the SPSSC website.

17 COACHES

- 17.1 Coaches are expected to conduct themselves with decorum during competitions. (Please refer to **Annex E**).
- 17.2 Coaches are not allowed to approach the officials to query their decisions. Only TMs or team captains are allowed to approach the officials to seek clarifications.
- 17.3 Schools must ensure that their coaches adhere to the SPSSC Rules and Regulations and Code of Conduct (Please refer to **Annex A** for coaches' oath).

18 SUPPORTERS

- 18.1 Schools sending supporters to any competition shall ensure that their students are in proper school uniform and that there are sufficient teachers present for student care and management.
- 18.2 All supporters are required to remain within the stipulated area for supporters throughout the competition. They are not allowed to be in the competition arena.
- 18.3 Participating schools must ensure that their supporters attending the competition(s) conduct themselves properly (Refer to Annex A). In the event that unsportsmanlike behaviour is observed, the Convenor may, at his discretion, issue an eviction of the supporter(s) from the training / competition venue.

19 BREACH OF CODE OF CONDUCT BY TMs / PARTICIPANTS / OFFICIALS / COACHES

- 19.1 A Disciplinary Panel comprising members of the NSGOC will be formed to investigate the breach, presided by a Principal, who is the Chairman of the Discipline Sub-Committee. The NSGOC Disciplinary Committee may co-opt members outside the Games Organizing Committee, including personnel from the national sports association, to provide technical advice.
- 19.2 Appeal against the decision of the NSGO Disciplinary Committee may be submitted by the school (for participants, coaches, and TMs) and/or the official, to the Council, whose decision shall be final (Please refer to Para 13 with regards to the Appeal process).

20 DISQUALIFICATIONS

- 20.1 A school will be disqualified if:
- a) it fields an ineligible participant who is:
 - i. overaged
 - ii. underaged
 - iii. unregistered
 - iv. suspended (with reference to para 14)
 - v. without a valid student pass
 - vi. not a bona-fide student of the school
 - b) its participant(s) are not accompanied by a TM
 - c) its participants caused a game / match to be abandoned
- 20.2 All results involving the team which has been disqualified will be considered null and void.

21 ATTIRE

- 21.1 All participants must be suitably attired in accordance with the requirement of the sport. The attire should bear the school colours / logo / badge or name.

22 OTHER RULES & REGULATIONS

22.1 Playing Time

The playing and interval time for the competition will be as follows:

	Entire competition
Playing Time	Four quarters of ten (10) minutes
Interval Time	Three (3) minutes, five (5) minutes and three (3) minutes between the first and second quarters, second and third quarters and third and fourth quarters respectively

22.2 Team Bench Area

Only the registered participants, TMs, registered officials and coaches (a maximum of three) are allowed within the team bench area (only the names reflected on the team respective day registration form). No unregistered participants, coaches, parents, ex-students or supporters are allowed.

22.3 Coaching During The Game

Team officials and bench players may coach while play is in progress provided that they remain seated or stand at their Team Bench. Coaching is also allowed during intervals and during stoppages but Team officials and bench players may not indulge in appropriate comments or behavior.

22.4 Stoppage for Injury Time

22.4.1 Requests for injury time may be made at the discretion of the teacher in-charge/ team captain/ player. Only the Teacher in-charge and/ or the First Aider may go on court. Aligned to INF 2016, all stoppages for illness/ injury or blood on the player are now 30 seconds and the player concerned must leave the court.

22.4.2 Coaching is permitted during any stoppage by any Team official who may approach the players at the sideline but play must restart in 30 seconds. Bench players may approach the sideline if coaching occurs. During a stoppage any Team official may approach the players at the sideline for the purpose of providing rehydration.

22.5 SPSSC Rules Not In Accordance to the INF Rules 2018

22.5.1 With reference to INF 2018 Rule 7.1.3 (iv), for SPSSC Netball, the player taking a penalty pass has to wait until the infringer stands out of play. A player who did not wait until the penalty is 'set' will be penalized.

22.5.2 With reference to INF 2018 Rule 10.2 (ii) (b), for SPSSC Netball, a defender may not deflect a shot at goal on its downward path towards the ring (this includes touching the ball up through the net). However, a defending player may not be lifted to deflect a shot.

22.5.3 With reference to INF 2018 Rule 5.1.2 (i), for SPSSC Netball, a team may have up to three team officials – Team Manager, Coach, and First Aider. The captain is no longer listed as a 'team official'.

22.5.4 With reference to INF 2018 Rule 5.1.2 (ii), for SPSSC Netball, the Teacher-in-charge is responsible for advising an umpire if a player is too ill/injured to leave the court within 30 seconds.

22.6 Substitution

All participating teams will need to make three (3) compulsory substitutions for each game. These three (3) compulsory substitutions can be made during any of interval times or half time. This will allow a minimum of 10 registered players to play for each game.

22.7 Playing the Ball

In the Junior Division games, a player who has caught or held the ball shall play it or shot for goal within four (4) seconds.

22.8 Height of Goalpost

The height of the goalpost for Junior Division is 2.6m.

23 Matters Not Provided For

All matters not provided for in these Rules and Regulations shall be dealt with by the SPSSC Netball NSGOC.

24 Amendments

The Singapore Primary Schools Sports Council (SPSSC) and SPSSC Netball NSGOC shall have the right to delete, add or amend the rules and regulations laid down herein.

SINGAPORE PRIMARY SCHOOLS SPORTS COUNCIL (SPSSC)
AND SINGAPORE SCHOOLS SPORTS COUNCIL (SSSC)

Mission, Motto and Aspirations

Mission Statement

“To provide quality competition experience to our school athletes to support character development through the pursuit of sporting excellence”

Motto

“Character in Sporting Excellence”

Aspiration 1: *Every athlete an honourable sportsman*

Guiding Principle:

The athlete abides by the rules of the game, gives his best in training and competitions, wins humbly and loses graciously. He participates actively and is committed to the skills development in his sport. He respects his opponents, teammates, coaches, teachers and officials, and displays exemplary conduct both on and off court.



ATHLETES' OATH

**“In the name of all competitors
we promise that we shall take part
in these National School Games,
respecting and abiding by the rules which govern them,
committing ourselves to the true spirit of sportsmanship,
without doping and without drugs,
for the glory of sport
and the honour of our teams.”**

(Revised version 2015; Adapted from the Olympic Athletes' Oath, 1999)

Character in Sporting Excellence

Aspiration 2: *Every teacher and coach an inspiring role model and mentor*

Guiding Principle:

The teacher/coach endeavours to develop each athlete to his fullest potential. He focuses on student-centric and values-driven coaching. He maintains a professional relationship with the athletes and ensures their safety and well-being at all times. As a positive role model, he inspires and motivates the athletes towards greater heights.



COACHES' OATH

*In the name of all the coaches,
we promise to respect all athletes,
officials and coaches in these
National School Games.*

*We shall act in the best interest of the
athletes and schools,
without doping and without drugs.*

*We commit ourselves to ensure that the
spirit of sportsmanship and fair play is
fully adhered to and upheld always."*

(Revised 2016; Adapted from the Olympic Coaches' Oath, 2012)

Character in Sporting Excellence

Aspiration 3: *Every official a fair, respectable and competent authority*

Guiding Principle:

The official is well-versed in the rules of the sport, and enforces the laws of the game with impartiality. He is alert and acts decisively when required. He ensures safety for all athletes and explains the rules when required. He upholds the professionalism of the sport.

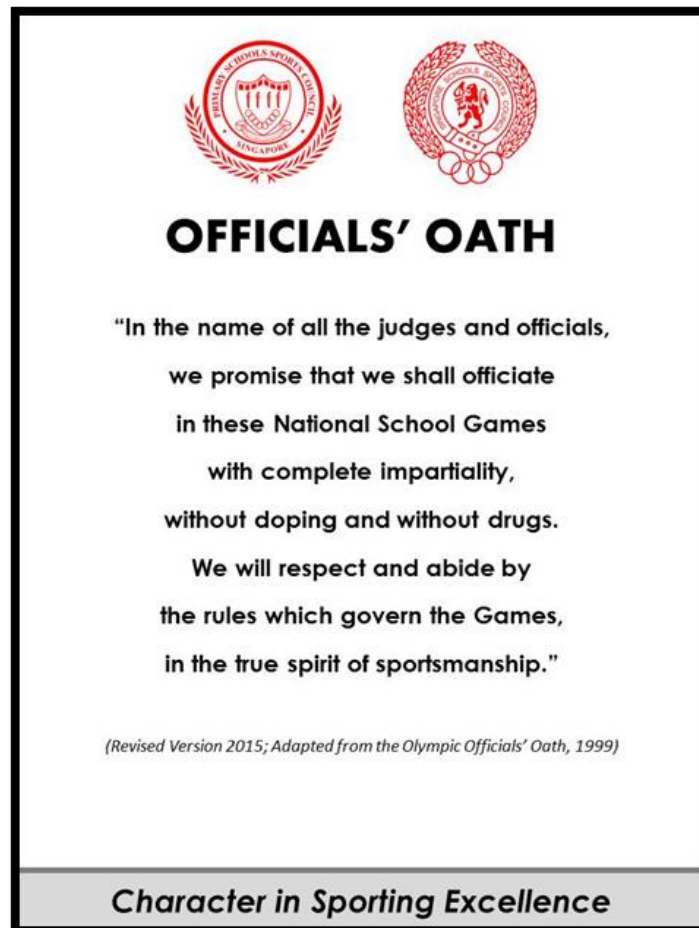

Aspiration 4: *Every parent a supportive partner*

Guiding Principle:

The parent takes interest in his child's training and competitions. He ensures proper nutrition and rest, and actively enquires on his child's progress and development. He works with the teacher and coach, attends games and respects the referee's decisions.

Aspiration 5: *Every spectator a respectful, responsible and caring motivator*

Guiding Principle:

The spectator makes the effort to applaud excellence and fair play. The spectator shows appreciation for the efforts of all athletes, teachers, coaches, officials and organisers. He should cheer to encourage and motivate as well as care for the athletes' well-being. The parent takes interest in his child's training and competitions. He is responsible and keeps the venue safe and comfortable for all.



SPECTATORS' CREED

Be a Respectful Supporter

- Applaud excellence and fair play
- Appreciate the efforts of all athletes, teachers, coaches, officials and organisers

Be a Caring Motivator

- Cheer to encourage and motivate
- Care for athletes' well-being

Be a Responsible Spectator

- Keep the venue safe and comfortable for all
- Keep the venue clean

Character in Sporting Excellence

Aspiration 6: *Every game a safe and enriching learning experience*

Guiding Principle:

The format of competition is developmental and age-appropriate. The games provide athletes with the opportunity to display their sporting prowess, and be recognised for their achievements. Athletes enjoy the competitions, which are conducted under safe and conducive environments.

Management of Appeal for Late/Erroneous Registration Workflow

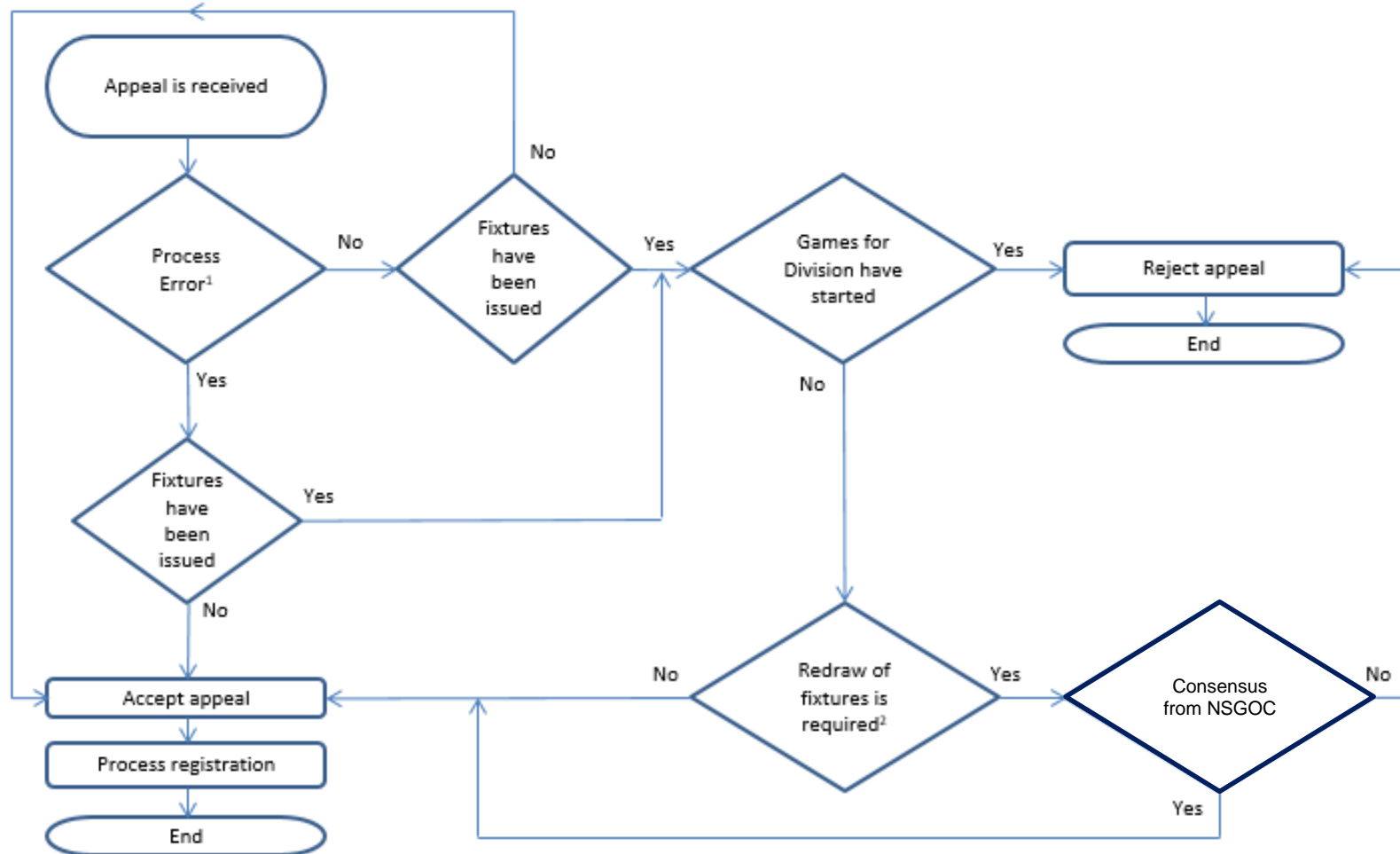

Note:

¹: Refers to errors such as technical glitches, miscommunication by Organiser, erroneous information by Organiser, etc.

²: Required if (i) appellant is a seeded team, (ii) there is change in format/number of groups

SPSSC PROCEDURE FOR APPEALS
WORKFLOW

3-4 weeks or earlier for entire process to complete
(suggested timeline)

STAGE 1

SCHOOL MAKES AN APPEAL IN WRITING TO SECRETARIAT/SPSSC and THE APPEAL MUST COMPLY WITH THE SPSSC GENERAL RULES AND REGULATIONS PARA. 12

This must be done **within two working days** upon receiving the NSGOC's Decision.

STAGE 2**PART 1 - ACKNOWLEDGEMENT OF LETTER OF APPEAL**

Upon receiving the official Letter of Appeal and the \$300 (via journal transfer), SPSSC Secretariat will acknowledge the date and time the letter is received.

PART 2 - SUSPENSION/RESUMPTION OF CHAMPIONSHIPS**STAGE 3****FORMATION OF SPSSC BOARD OF APPEAL**

Chairman/SPSSC Discipline & Appeals Sub-Committee to convene a Board of Appeal (BoA) to look into the matter and also provide a timeline for completion.

STAGE 4**OUTCOME AND CLOSURE OF SPSSC BOARD OF APPEAL**

BoA Secretariat will arrange for a meeting with appellant (school) and all relevant parties to inform decision and explain process.

As in accordance with the SPSSC General Rules and Regulations under rule 12.4, the decision of the Board of Appeal or the Standing Committee shall be final.

SINGAPORE PRIMARY SCHOOLS SPORTS COUNCIL

Role of the Team Manager

The team manager (TM) will represent the school on all matters pertaining to the duty of care, student management and competition matters relating to the participants from his / her school. He/she must be a good role model for the participants and are expected to conduct themselves well in carrying out their duties. He/she will do the following:

	Terms of Reference
1	Point of contact between the National School Games Organising Committee (NSGOC) and the Principal (school).
2	Attend all briefings and/or meetings called for by the respective NSGOCs.
3	Check & verify the fixtures and schedules involving the school.
4	Ensure the accuracy of participants' particulars in the registration and that students are not placed in the wrong division.
5	Make transport arrangements for the participant(s).
6	To chaperone participant(s) to and from the competition venue and remain with the participant(s) throughout the duration of play.
7	Cooperate with NSGOC & officials and abide by the rules and regulations of the competition.
8	Submit team list & other necessary documents when required to.
9	Manage the coach, participant(s) and supporter(s), if any, to ensure that they adhere to the Code of Conduct as provided in SPSSC Rules & Regulations.
10	Arrange for a replacement, in the event that he/she is not able to perform his/her duty, including when it is halfway through the competition
11	Duty of care for the participant(s) safety and well-being and to ensure that the participant(s) is/are medically covered e.g. first aid kit.
12	Contact the school immediately in the event of an injury or emergency.
13	Do not speak to the media unless with permission from the school
14	Represent the school in matters pertaining to formal appeals/protests (as required by the sport)
15	Accompany participant(s) at disciplinary board meetings if the occasion arises.
16	Any other matters pertaining to the duty of care, student management and competition matters relating to the participants from his / her school.

Code of Conduct for Coaches

- Coaches must be good role models for the student athletes and are expected to conduct themselves well in carrying out their duties.
- They are to observe the rules and regulations of the National School Games and honour the Coaches' Oath.
- They should not replace the role of the team manager.
- They are to prepare the training schedule for the team, in consultation with the Principal and the teacher in-charge (i.e. 30-week programme)
- They are not allowed into the competition area except where the rule of the sport requires the presence of the coach e.g. Softball and Gymnastics.
- They cannot represent the school in any matter.
- They must not interfere with the organisation of the competition.
- They are not allowed to approach the game officials to query their decisions. Only team managers are allowed to approach game officials to seek clarifications.
- Coaches violating the rules will be asked to leave the competition arena.
- Action will be taken against the school if the coaches fail to comply with the competition rules.
- The onus is on the coaches to adhere to the rules and to be well versed with the competition rules amended to meet the needs of the student athletes lies with the school concerned.
- They must ensure that the student athletes have adequate rest and given water breaks.
- Coaches should refrain from using foul language or in a tone not becoming of proper behaviour.